

MINI-SCENE®

THE WINDMILL M103



INSTRUCTIONS

The Mini-Scene General Instructions accompany the below instructions. Refer to both when assembling this kit.

1. Clean and fit Castings.
2. Paint and turf Mound.
3. Assemble and glue Parts 1 (4 pcs) as illustrated (Fig. 1a and 1b). Be sure supports and flanges face out.
4. Slide Part 2 over top of Part 1 Assembly until it rests on flanges (Fig. 2). Glue in place. **NOTE:** If opening in Part 2 is too narrow, enlarge it using a file or sandpaper.
5. Glue Part 3 to top of Framework (Parts 1). Glue Part 4 to Part 3. (Fig. 2)
6. Paint Castings.
7. Glue Parts 5 - 8 to Mound (Fig. 3).
8. Glue Windmill to Mound (Fig. 4).
9. Prepare and assemble Trees (See section E. "Assemble Trees" in Mini-Scene General Instructions), then glue to Mound where noted (Fig. 4).
10. Add finishing touches. Clear an area on layout and attach Mini-Scene using Scenic Glue™ (S190). Use leftover landscape material to blend Mound into existing landscape, or mount in a Glass Display Dome and Base (M127).

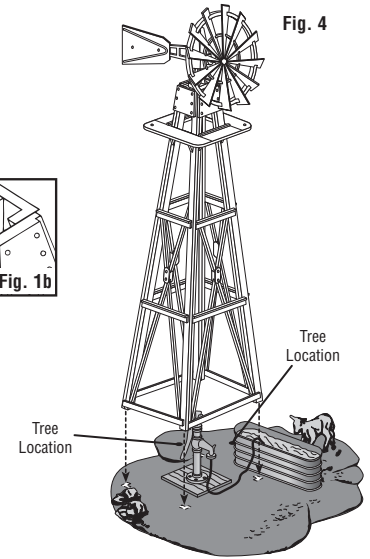
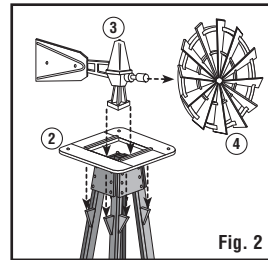
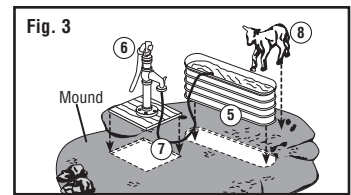
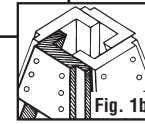
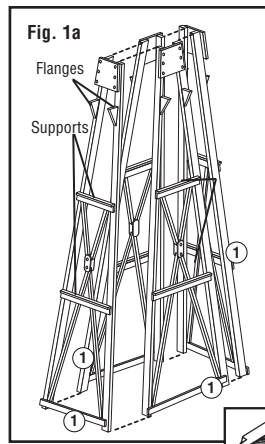

MINI-SCENE GENERAL INSTRUCTIONS

Read through all instructions before beginning. See reverse side of box label for exploded view and assembly instructions specific to your kit.

This kit contains everything required to build the Mini-Scene except paint and glue. This Mini-Scene can be finished in pewter patina or painted as a realistic scene for display. It can also be built into a scene for a HO scale model railroad layout or as a complete scene for display.

We recommend the Mini-Scene® Paint Set (M125), which includes 12 assorted colors and instructions on how to realistically paint, detail and weather scene kits. The paint is non-toxic, non-flammable and water-soluble. For a quality pewter finish we recommend Pewter Patina Finish (M126), easily applied by brushing on, then wiping off high spots. The finish is non-toxic, non-flammable and water-soluble.

Woodland Scenics offers a Glass Display Dome and Base (M127) to permanently display and protect your Mini-Scene (see back of box).

Suggested materials for assembling Mini-Scene Kit

Hobby Knife
Cyanoacrylate adhesive (CA glue/super glue) or fast-setting epoxy
Mini-Scene Paint Set or high-quality, matte hobby paint
Paintbrushes
Tweezers
Small file
Scenic Cement™ (S191)
Scenic Glue™ (S190)

A. CLEAN AND FIT CASTINGS

Mini-Scene Kits are composed of Metal Castings. Due to the molding process, Castings need to be examined and cleaned prior to priming and painting. Parts could have parting lines (seams), flash (thin film of excess metal at seams) and stems. Remove this excess material with a hobby knife, file or sandpaper.

If pieces are irregularly warped or bent, flatten by placing on work surface and pushing down gently on high areas.

Test fit Castings. If interlocking pieces do not fit together properly, remove excess metal with a hobby knife or file.

Wash Castings in warm, soapy water with a mild detergent to remove any remaining mold-release residue. Rinse well and let dry. Castings are somewhat brittle and should be handled carefully, except for Tree Armatures which are highly bendable.

B. PAINT AND TURF MOUND

Prime Mound with White Paint from the Mini-Scene Paint Set or use a good metal primer.

In preparation for applying Turf, paint the earth areas of the Mound an earth/brown color. If mound has other details such as rocks, concrete blocks or boards, paint these items as desired. Let dry.

After paint is completely dry, apply Turf to earth areas. Spray Scenic Cement onto Mound where Turf is desired. Sprinkle Turf onto wet glue. Repeat until desired coverage has been achieved. Spray Scenic Cement between layers of Turf. When Turf application is complete, spray a final light coat of Scenic Cement on and let dry.

C. PRIME AND PAINT CASTINGS

Bend and twist Tree Armatures into realistic three-dimensional tree shapes prior to priming and painting.

Use metal primer to prime Castings. Let dry. Paint Castings following the color scheme indicated on front of Mini-Scene box or paint as desired. Paint Tree Armatures a base color. When dry, add highlights to trunk with a color wash or drybrush paint technique. These techniques are explained in the Mini-Scene Paint Set instructions.

We recommend weathering Castings after they are painted to add realism. Weathering creates an old, soiled or weathered look as opposed to a freshly painted look. There are many techniques for weathering, and experimenting is recommended. Applying a color wash (paint thinned to a transparent consistency) is a good and easy technique. Usually, a very light shade or a very dark shade is most desirable. The shade should be in contrast with the color of the item being weathered.

D. ASSEMBLE CASTINGS

Glue Castings with cyanoacrylate adhesive (super glue) or fast-setting epoxy. When using super glue, surface contact is necessary for a good bond. Super glue is not a filler-type glue. It should also be used sparingly. Too much glue creates a poor bond.

Apply a small drop of glue on only one side of the parts to be glued together. Join the parts and hold together firmly for about 10 seconds.

When using super glue with larger Castings, hold parts together and apply a drop of super glue where parts touch. Because of capillary action, glue will seep into the area between the parts. Hold parts in position until setting begins. If there is a void where parts touch, fill the gap with Scenic Glue or epoxy. When larger parts have good bond, add additional super glue to the entire contact area and allow it to seep into seams.

Tweezers are recommended when gluing small parts together. When gluing Castings to a turfed area on the Mound, scrape Turf off the area where Castings make contact.

Some Mini-Scenes include Wire. If the wire needs to be shaped, it is easy to do with your fingers. To straighten bent Wire, hold one end firmly, and with thumb and index finger, pull the Wire straight several times.

E. ASSEMBLE AND MOUNT TREES

When handling Foliage, some turf ("leaves") will fall off. Work on a clean surface so you can save excess turf to use as additional ground cover later. Cut or tear the Foliage into the same number of pieces as there are Tree Armatures in your Mini-Scene Kit.

Stretch each piece of Foliage to about twice its original size. It should be thin, lacy and three-dimensional in quality. Do not worry about stretching it too much, it cannot be damaged.

Arrange stretched Foliage on Tree Armatures, retaining the lacy, see-through quality. Rearrange until satisfied with appearance. If you do not like the appearance of your Trees, remove the Foliage and reapply it. If you have leftover Foliage, use it for vines, weeds or bushes.

Spray Foliage with Scenic Cement to seal it in place. If desired, sprinkle on some of the excess Turf and spray with Scenic Cement to seal in place. Trim undesired strands of Foliage with scissors. Apply a few spots of Scenic Glue where Foliage touches the branches to secure in place permanently. Repeat the above process until all Trees are complete.

The Mound has holes for planting Trees. If a hole is too small for the base of the Tree's trunk, ream out the hole by carefully rotating the point of a hobby knife into the hole until the trunk fits. If the hole is too large for the tree trunk, carefully squeeze the base of the trunk with pliers to flatten it out until it fits the hole. Glue Trees in place with Scenic Glue or cyanoacrylate adhesive (CA glue/super glue).

F. FINISHING TOUCHES

"Leaves" that fell off Foliage material can be added to Turf to add ground texture. Secure with Scenic Cement. Stretch small pieces of extra Foliage into vines or shape into weeds and bushes to add to Turfed area on Mound.

If you feel your scene needs more color, consider repainting a few small items in very bright colors, such as a man's shirt, a bucket, a barrel or any other appropriate item.

Small touches add extra realism to your scene. Accentuate Turf by adding thinned paint to certain areas. If the kit has green Turf, paint on spots of brown to model a dried area or one that has been worn away by erosion. If Turf is brown, paint on a few spots of green to model the beginning of plant life. If the scene includes anything that should have water in it, such as a bucket, add Realistic Water™ (C1211).

Lightly spray the entire Mini-Scene with Scenic Cement when complete. Let dry.

G. MOUNT MINI-SCENE

The Woodland Scenics Glass Display Dome and Base makes an excellent display for a Mini-Scene and provides good protection. To mount the Mini-Scene to the base, we recommend epoxy cement, cyanoacrylate adhesive or double-sided tape.

The Mini-Scene can also be mounted to other bases with these adhesives. You may wish to mount the scene to a piece of driftwood, a rock or in a shadow box.

When adding the Mini-Scene to a model railroad layout, remove any existing Turf and glue in place. To conceal the edges of the mound, sprinkle on excess turf from Foliage and attach with Scenic Cement. You can also add Plaster Cloth around the edge of the Mound, feather it out and cover with Earth Undercoat (C1229) and Turf material.

H. ALTERNATIVE - PEWTER PATINA FINISH

The Pewter Patina Finish highlights the detail in the Castings and makes them appear naturally aged. When using the Pewter Patina Finish, the colored Foliage and Turf will not be used.

1. Clean and fit castings (see Instruction A).
2. Shake bottle of Pewter Patina Finish well. Brush onto Castings and wipe off before dry. Leave Pewter Patina Finish in recessed areas. Bend and twist Tree Armatures into realistic three-dimensional tree shapes before applying Finish. Let dry.
3. Follow Instruction D for general assembly information and instructions on reverse side of box label for specifics on assembling your Mini-Scene.
4. The Light Gray Foliage material is for use with Pewter Patina scenes. Cut or tear it into the same number of pieces as there are Tree Armatures. For a darker appearance, paint Foliage with Pewter Patina Finish.
5. Stretch each piece of Foliage until it is twice its original size. It should be thin and lacy, three-dimensional and irregular in appearance. Arrange on Tree Armature until satisfied with appearance. Spray Foliage with Scenic Cement to seal in place. Trim undesired strands of Foliage with scissors. Apply a few spots of Scenic Glue where Foliage touches branches to secure permanently. Repeat above process until all trees in kit are complete.
6. Plant Trees as indicated in Instruction E. Lightly spray the entire Mini-Scene with Scenic Cement when complete.

Conforms to Health Requirements
of ASTM D4236

Model making product. Not a toy! Not suitable for children under 14 years! / Produit pour le modélisme. Pas un jouet! Pas adapté aux enfants de moins de 14 ans! / Producto para modelismo. No es un juguete! No adecuado para niños menores de 14 años! / Modellbauartikel. Kein Spielzeug! Nicht geeignet für Kinder unter 14!