

# DPM® LANDMARK STRUCTURES® N SCALE BUILDING KIT



## CHAR'S SODA SHOPPE #50400

### INSTRUCTIONS

#### Read through instructions before beginning construction.

Use plastic cement to glue parts. Plastic cement works by dissolving the surface of plastic and welding parts together. Be careful to avoid contact with detail on parts and visible areas on Clear Window Material. Always allow glue to set thoroughly before moving on to next construction step.

#### Prepare Building Parts

Wash Walls, Door and Chimney Backs in warm, soapy water, rinse and let dry. Use a hobby knife and sandpaper to remove excess plastic (tabs and flash) that occurred during the molding process.

**Tab:** Score flush with part, snap off and sand smooth. **Flash:** Lightly scrape along edges to remove debris and sand smooth. Face cutting edge of blade opposite the scraping direction to avoid cutting into detail on Walls.

#### Square Draft Angles

Wall edges are angled (draft angles) to make removal from mold easier. Draft angles need to be sanded square to allow for proper assembly and a flush fit with adjoining Walls. To square edges, thumbtack a piece of 120-grit sandpaper to a board and draw Wall back and forth evenly on sandpaper until edge is square and level (Fig. 1). Edges to be sanded square do not have brick detail and are marked "A" (Fig. 2).

#### Door Side Panels

- Using Side Panel material (white styrene strip), cut two Entry Door Side Panels (504-6) the same height as Entry Door (504-7) (Fig. 4).
- Glue Side Panels to Entry Door (Fig. 2 and 4).
- Glue Front Door Assembly to back of Front Wall (504-1) (Fig. 4).

#### Chimney Backs

The Roof (504-8) will be glued to the bottom of the four Chimney Backs (504-5) (Fig. 3).

- File draft angle off bottom of Chimney Backs so top of Roof will set flush.
- Glue Chimney Backs in place (Fig. 4). When glue is set, file tops flat.

#### Wall Assembly

- Glue Front Wall (504-1) to Side Wall (504-2). Align brick courses while keeping bottom of Walls as level as possible and corners square. **TIP!** Use styrene Roof as a square.
- Glue Back Wall (504-3) to Side Wall (504-4).
- Glue Wall Assemblies to each other. Use rubber bands to hold building together while making final adjustments and drying.

#### Roof

- To make Roof (504-8), place building on Roof Material (white styrene) and trace around interior walls. Cut out and trim to fit as needed.
- Prime Roof and paint grimy black before installing.

**TIP!** Cut small squares of scrap Roof Material and glue to Roof to simulate roof hatches. Small details add realism and interest to your building. Paint before gluing in place.

#### Level Building

On thumbtacked piece of 120-grit sandpaper, carefully sand bottom of building in a circular motion to level bottom edges so it will sit level on layout.

#### Paint Building and Details

Apply a thin coat of primer before painting and let dry.

**Airbrush:** Use solvent-based, flat finish enamel paint.

**Hand-brush:** Use water-soluble, flat finish acrylic paint.

**Aerosol:** Use flat finish spray paint.

We recommend natural brick colors such as rust, tan or other earth tones. Paint door and window trim the same color as the brick or a contrasting color.

#### Weathering Tips

Add a realistic mortar-look to brickwork by painting on a concrete mortar wash (formula follows). Using a paintbrush, dab on small amounts of wash until desired look is achieved. Sponge off excess.

**Formula:** Mix 1-part acrylic paint (color suggestion: concrete or aged concrete), 12-parts rubbing alcohol, 8-parts water and 1 drop liquid dish soap.

**Airbrush:** Lightly spray thinned flat black paint (color suggestion: grimy black) to areas where natural discoloration can occur (near windows, chimneys, etc.).

**Chalk:** Rub a dark color of pastel chalk (color suggestion: gray, black, brown, etc.) on sandpaper to create a chalk dust. Using a paintbrush, dab chalk dust where discoloration can occur.

#### Install Windows

- Cut Clear Window Material (clear styrene) to size to fit over an entire area of window openings at one time.
- Center Window Material over windows on inside of building and carefully dab a small amount of glue around edges.
- Repeat for each set of window openings.

#### Install Roof

- Install Roof (504-8) through bottom of building and glue to bottom of Chimney Backs (Fig. 3).
- Cut two Roof Supports (504-9) to fit the length of Walls (504-1) and (504-3).
- Glue one Roof Support to bottom of Roof and along Front Wall and one to bottom of Roof and along Rear Wall (Fig. 3).

#### Finishing Touch

Give your building the illusion of being occupied. Place a piece of black construction paper diagonally from corner-to-corner inside the building to block the light.

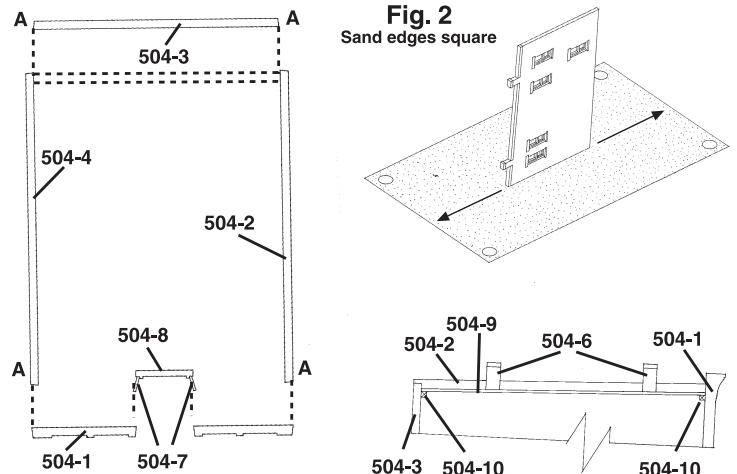

Fig. 1  
Plan (View from Top)

Fig. 3  
Cross Section

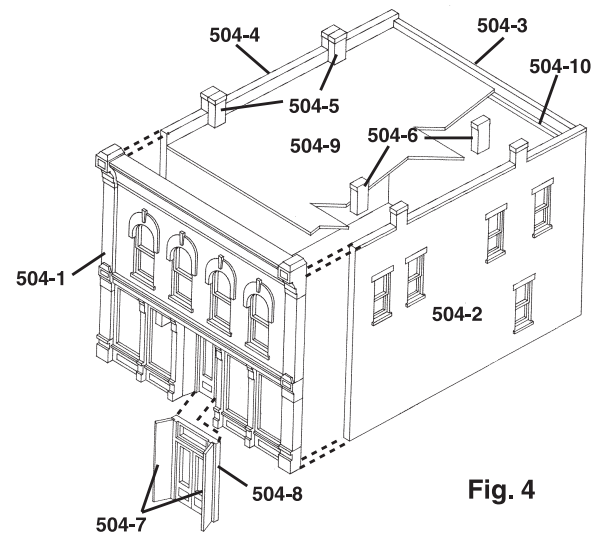

Fig. 4

Create interest on your layout. Add lights to your buildings quickly and easily using the Woodland Scenics® Just Plug® Lighting System.

**CAUTION:** Cutting tools recommended. Use with care. / **ACHTUNG:** Schneidwerkzeuge empfohlen. Mit Vorsicht benutzen.

**MODELING AND CARE INFORMATION** This kit suggests the use of materials that may stain or cause damage. Take care to cover project area and clothing appropriately. Follow recommendations for use and cleanup.

Model making product. Not a toy! Not suitable for children under 14 years! / **Produit pour le modélisme. Pas un jouet! Pas adapté aux enfants de moins de 14 ans! / Producto para modelismo. No es un juguete! No adecuado para niños menores de 14 años! / Modellbauartikel. Kein Spielzeug! Nicht geeignet für Kinder unter 14!**