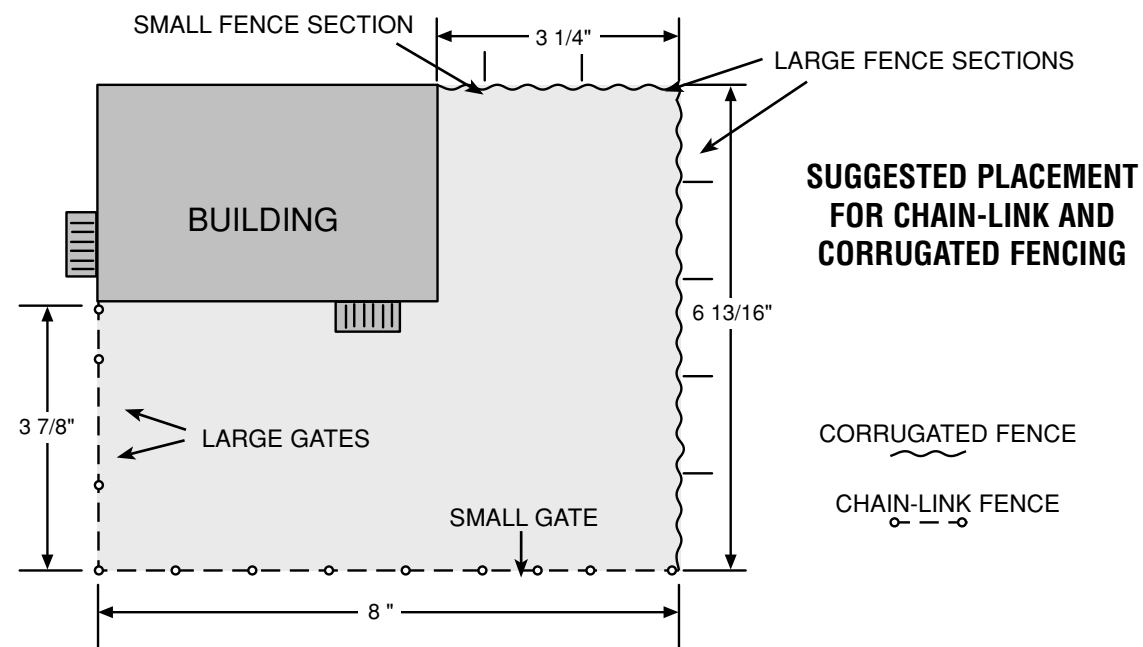
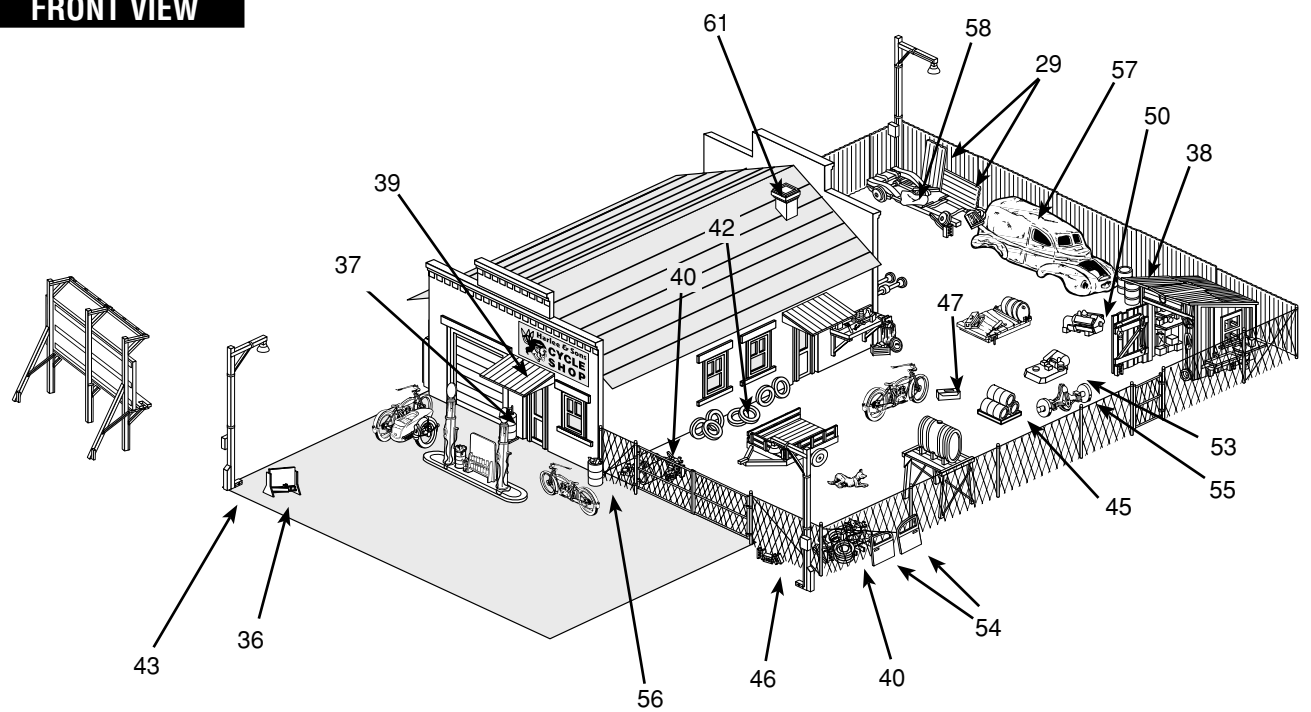

FIG. 13



SUGGESTED PLACEMENT FOR WHITE METAL CASTINGS AND ACCESSORIES

FRONT VIEW



BACK VIEW

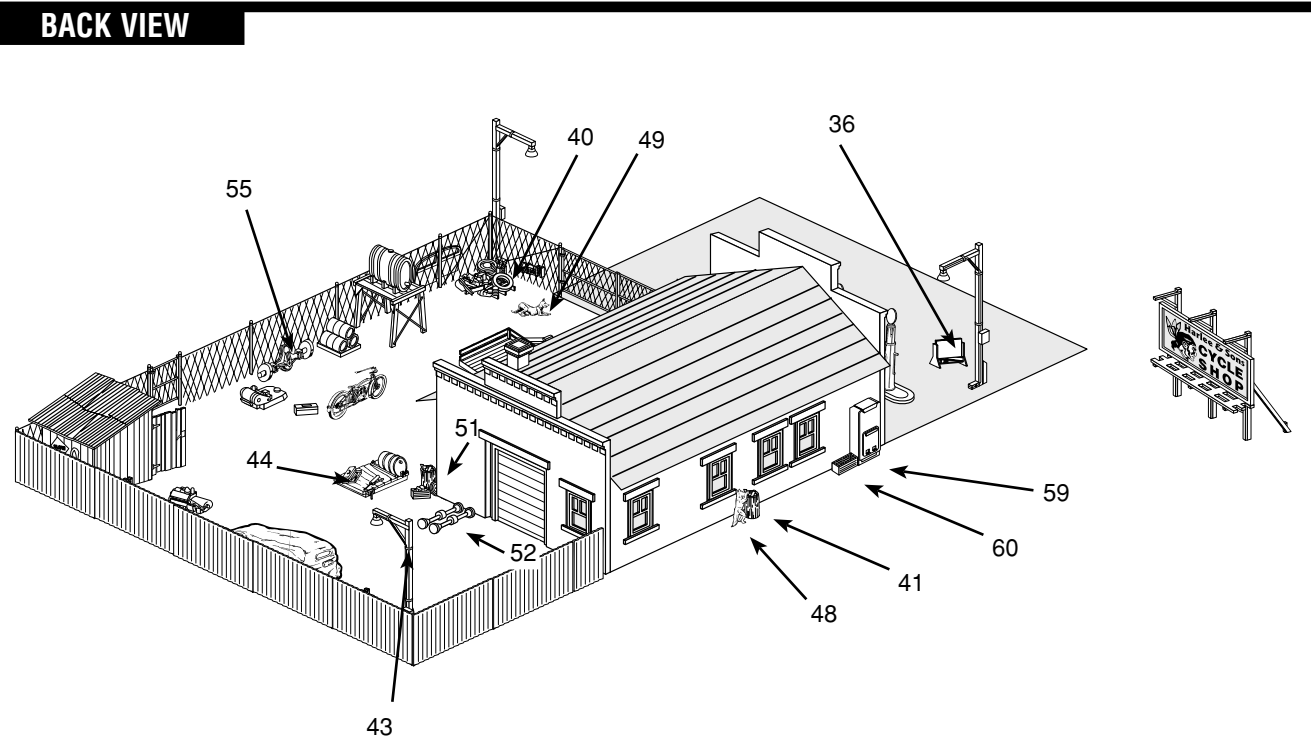

#406 HARLEE & SONS CYCLE SHOP INSTRUCTIONS



DESIGN PRESERVATION MODELS
 P.O. BOX 66
 LINN CREEK, MO 65052 USA
 www.dpmkits.com

MADE IN USA

© 1999 DPM

WHITE METAL CASTINGS & PARTS LIST:

The following list contains all details included with the 406 kit. After cutting parts from sprues, sort and organize them. This will make assembly easier.

	Part No.	Name	Qty.	
CYCLE SHOP		Styrene plastic walls	4	
BILLBOARD	1	Billboard	1	
	2	Catwalk	1	
	3	Light bar	2	
	4	Outer brace	2	
	5	Inner brace	1	
MOTORCYCLE AND SIDECAR	6	Handlebars	3	
	7	Motorcycle body	3	
	8	Sidecar	1	
	9	Sidecar wheel	1	
GAS PUMP	10	Base	1	
	11	Clear rod	2	
	12	Cap	2	
	13	Pillar	2	
WORK BENCH	14	Work bench	1	
	15	Wall bracket	2	
FUEL STAND	16	Fuel tank w/base	1	
	17	Stand legs	2	
TOOL SHED	18	Roof	1	
	19	Rear wall	1	
	20	Front wall	1	
	21	Right side wall	1	
	22	Left side wall	1	
	23	Door	1	
	TRAILER	24	Trailer base	1
		25	Short trailer side	1
26		Long trailer side	2	
27		Trailer wheels	2	
28		Trailer axle	1	
CORRUGATED		29	Small fence piece	3
	FENCE	30	Large fence piece	7

	Part No.	Name	Qty.
CHAIN LINK FENCE	31	Small gate frame	1
	32	Large gate frame	2
	33	Hinged post	3
	34	Corner post	4
	35	Line post	6
MISC. DETAILS	36	Sm. Signboard	1
	37	Barrel w/pump	1
	38	Oil barrel	1
	39	Door awning	2
	40	Junk piles	2
	41	Crushed trash barrel	1
	42	Tires	7
	43	Streetlight	3
	44	Pallet w/barrel	1
	45	Stack of 3 barrels	1
	46	Concrete blocks	6
	47	Toolbox	1
	48	Standing dog	1
49	Lying dog	1	
50	Engine block	1	
51	Trash can w/box of trash	1	
52	Axles	2	
53	Motor w/base	1	
54	Car doors	2	
55	Axle w/drive shaft	1	
56	Barrel w/trash on top	1	
57	Junked car body	1	
58	Junked car frame	1	
59	Soda machine	1	
60	Case of soda bottles	1	

ADDITIONAL MATERIALS INCLUDED: White Plastic Roof material - 1 (5 3/16" X 5 1/2") • Clear window material - 1 (5" X 5") • Black paper for roof and interior - 2 (4 3/4" X 5 1/8") • White plastic stick - 1 (5 3/16") • Wire for Fence and Gas Pumps - 2 (12") • Chain-link fence material - 1 (2" x 14") • Dry Transfer decal sheet - 1 • Full Color Poster sheet - 1 • Wax paper - 1 (12" x 10 3/4")

GENERAL INSTRUCTIONS

PREPARATION OF PLASTIC PARTS

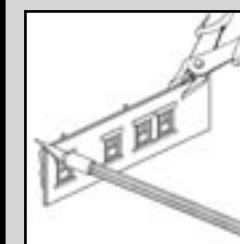

Use a hobby knife or diagonal cutters (i.e. Fiskars) to remove excess plastic created by molding process. Do not cut into details.

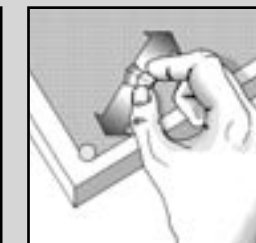
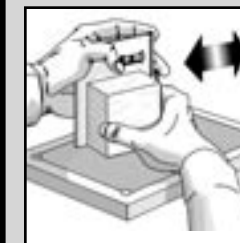

Sand draft angles (left from molding process) from edges of all the molded parts that will be glued until edges are flat. Tack 100 grit sandpaper to flat surface. Make sanding area longer than the longest wall of the model. Using squaring block, keep edges flat and hold panels square as you sand. Move wall panel, not the block. Sanding is essential to achieve proper fit later. Be careful not to sand into detail of buildings. Lightly sand or file the smooth sides and bottom of chimney for proper fit.

To glue plastic walls and pieces use plastic model cement or solvent.

PAINTING & DETAILING PLASTIC PARTS

PAINTING

We recommend airbrushing with solvent-based enamel paints, such as Floquil. Use water soluble flat paint such as Polly 'S' for brushing (color is your choice). See photo on box for suggested coloring. Paint roofs in flat tones and vary colors to resemble weathering and enhance shingle detail. Color of window and door frames can match or contrast with building. Building may be aged with chalks or lightly misted by airbrushing with thinned flat black paint such as Floquil Grimy Black. Small details painted in contrasting colors will enhance the building's appearance. See the photo on the box for painting ideas. Scrape paint from glue points as necessary. Walls and other parts may be painted before assembling. If buildings are painted after assembly, be careful not to paint over the clear window material.

OPTIONAL IDEA

To complete the illusion that the building is occupied, place black paper (included in this kit) diagonally from corner to corner inside building to block light from entering.

DRY TRANSFER DECALS

- A.** Place dry transfer decals in locations shown on front of package or where desired.
- B.** Place sheet with decal pressed against surface. Hold sheet firmly so decal will not move while applying. Rub top of sheet over desired decal with a burnisher or dull pencil.
- C.** Carefully remove decal sheet. If transfer was incomplete, let sheet fall back into place and repeat procedure.
- D.** Place backing paper over decal and reburish. Repeat with other decals.

TIP: If decals are fragmented, they can still be used. This effect adds a realistic, weathered look. **NOTE:** The cast details and Dry Transfers in this kit were made by Woodland Scenics for Design Preservation Models. See the entire line of Woodland Scenics Dry Transfers and castings at your favorite hobby store.

Look through the enclosed catalog to see the complete line of DPM buildings.

BUILDING:

1. Remove all parts from sprues. Clean and prep.
2. Glue walls together as shown in Fig. 1. Long walls will be glued to the inside edge of short walls.
3. Cut clear window material slightly larger than window frames. Glue windows and doors to inside of walls as shown in Fig. 1. Attach window material to back of window frames as shown in Fig. 1 with very small amount of glue placed around outer edges.

ROOF:

1. Cut white plastic square to form two roof sections to the dimensions indicated in Fig. 3.
2. To form ridge supports and roof stops, cut the white plastic stick as shown in Fig. 3.
3. Glue ridge support and roof stops to underside of roof sections as shown in Fig. 3.
4. Fit roof sections over walls as shown in Fig. 2. Peak of roof should fit below top of front and back wall facades. Roof stops should fit inside walls. Glue roof and walls together where they meet and roof sections at the peak.
5. Roof sections will overlap at the peak. Let glue dry. File overlap area as shown in Fig. 3A until peak is even.

ROOFING:

The 4 3/4" x 5 1/8" black paper furnished is used to represent roll roofing. Five strips are needed for each side of the roof with one strip being used for the ridge cap.

1. Measure front to back length of roof and trim 4 3/4" length of paper to match.
3. Cut 11 strips 7/16" wide (Fig. 3B).
4. Starting at the bottom of the roof, glue strips to roof panels overlapping each approximately 1/8 inch. Use five strips on each side.
5. Fold last strip in half lengthwise and use as the roof ridge cap.
6. A notch will need to be cut in one or two of the roof strips to accommodate the base of the chimney. See Fig. 2 and box photo for placement.
7. See "Painting & Detailing Plastic Parts" for ageing and weathering the roof material.

FENCE:

CHAIN-LINK FENCE:

- There are two large gates and one small gate.
1. Remove extensions from gate corners (Fig. 4A).
 2. Cut fence material slightly larger than gate (Fig. 4A).
 3. Lay the gate flat and apply glue to outside frame.
 4. Lay chain-link material over fence. Let glue dry.
 5. With a hobby knife carefully trim the chain-link material that extends beyond the outside frame. Repeat with other gates (Fig. 4A).

There are three types of posts: line posts, corner posts and hinged posts. There are also two 12" pieces of wire to model the horizontal and diagonal rails.

1. Tape supplied wax paper over fence drawing in Fig. 4 so that glued parts don't stick to instructions.
2. Cut wires to section lengths (1,2,3 & 4) designated in Fig. 4. If wire needs straightening, pull gently between two pliers.
3. Work with one fence section at a time and place fence pieces directly on the wax paper. Lay horizontal wire pieces down first and glue fence posts in place on top of wire. Glue diagonal wires in place and let dry.
4. Use a sharp hobby knife and straight-edge to get a straight side on chain-link fence material. Cut material slightly oversize. Apply glue to wire and posts. Align the straight side of the material to top wire of fence, place second piece of wax paper over assembly and hold until glue dries. Trim sides and bottoms as shown in Fig. 4.

CORRUGATED FENCE:

1. Cut extensions from top of corrugated fence panels (Fig. 5).
2. Lay flat and glue edges together as indicated in Fig. 5. Configure corrugated fence panels per Fig. 13.

PLACING FENCE ON LAYOUT:

1. Drill small holes in base to accept chain-link and corrugated fence posts and glue fence into position. See Fig. 13 for placement of each type of fence.

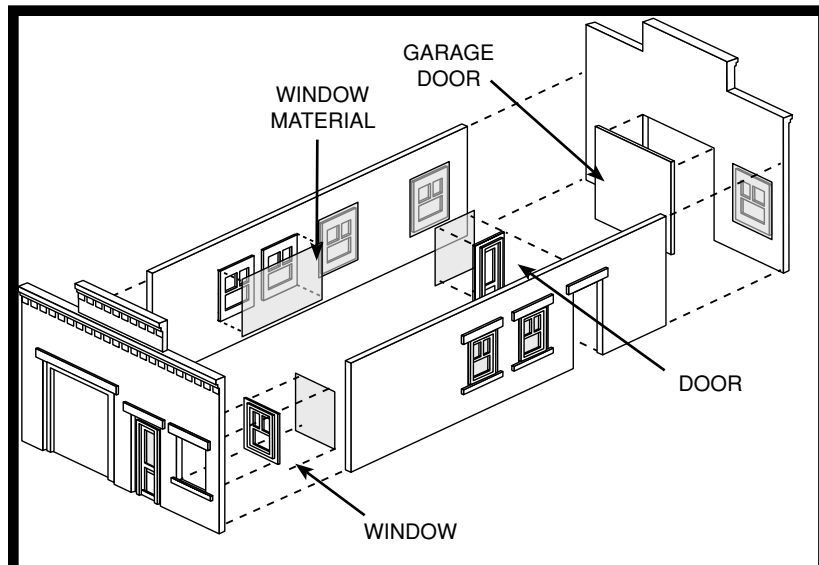

FIG. 1

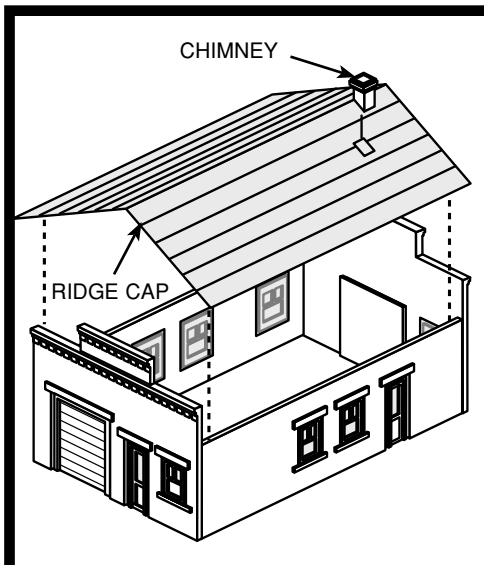

FIG. 2

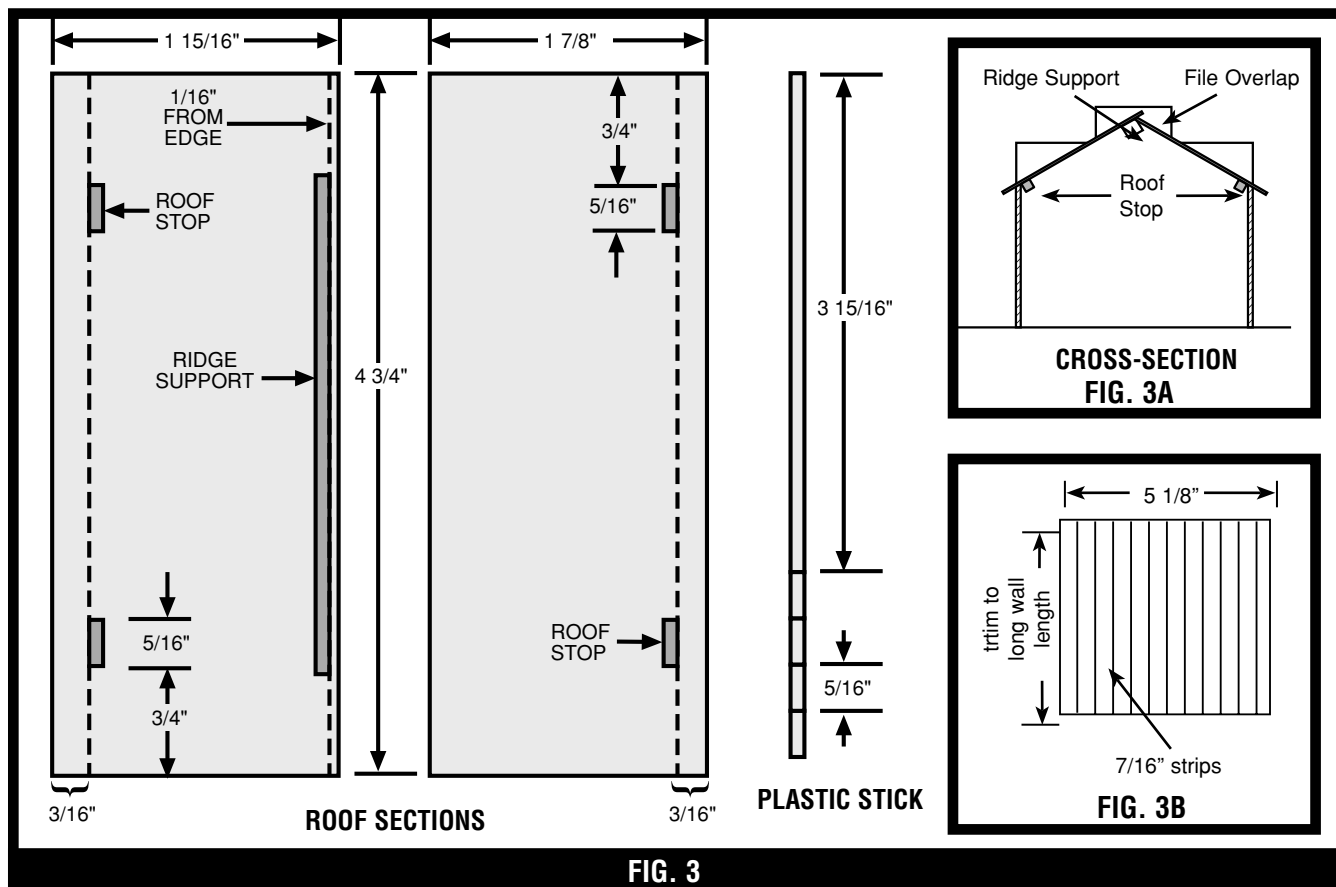

FIG. 3

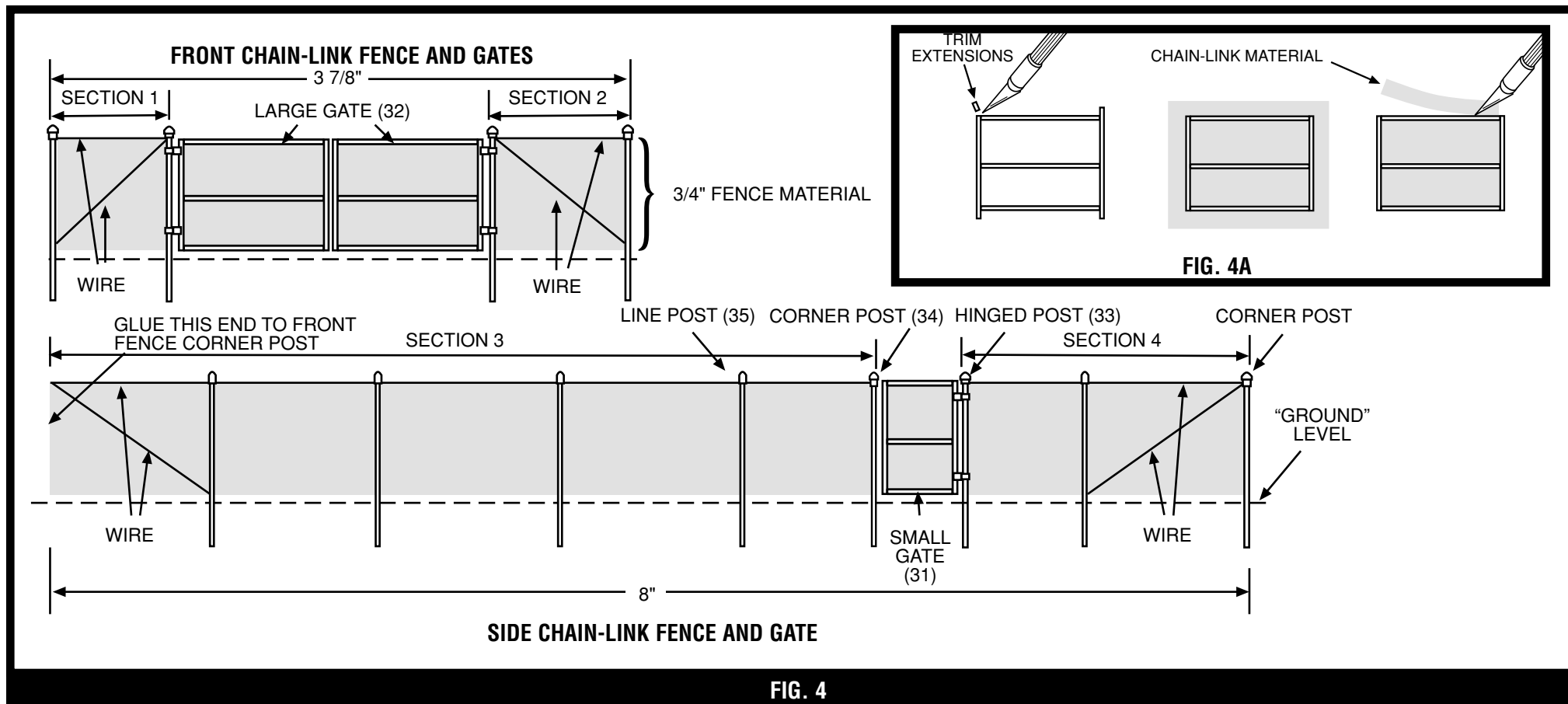

FIG. 4

PREPARATION OF WHITE METAL CASTINGS:

Remove parting lines, flash and stems with a hobby knife (i.e., X-Acto), diagonal cutters (i.e., Fiskars), sandpaper or file. Test fit castings. Note: Castings bend easily and should be handled carefully. Straighten bent or warped castings.

Wash all metal castings in soapy water to remove residue caused by molding process. Rinse and allow parts to dry.

Plan ahead. It is often easier to paint certain castings before assembly. We recommend using a solvent-base spray primer coat and then painting castings with a high quality, water base flat paint. If you paint, scrape paint from glue points before gluing and touch up paint if necessary after assembly. Glue castings together with a fast-setting epoxy or cyanoacrylate such as "super glue." (A thick, gap-filling cyanoacrylate is recommended.)

DETAILS INSTRUCTIONS:

1. Assemble white metal castings (FIGS. 6 - 12). Paint if necessary.
2. Apply decals as shown on box or where appropriate.
3. When painted details are dry place them on layout. See Front and Back View illustrations and photo on box for suggested placement.

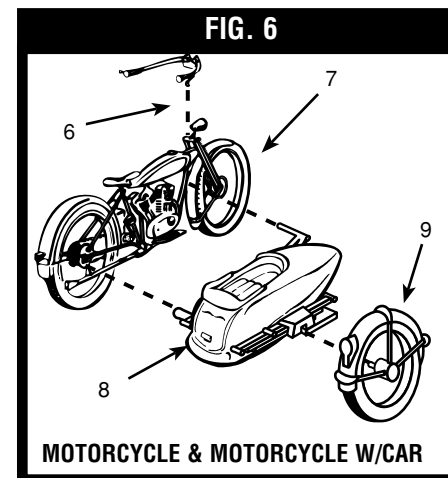

MOTORCYCLE & MOTORCYCLE W/CAR

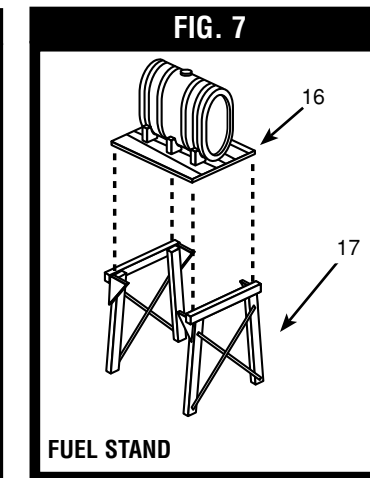

FUEL STAND

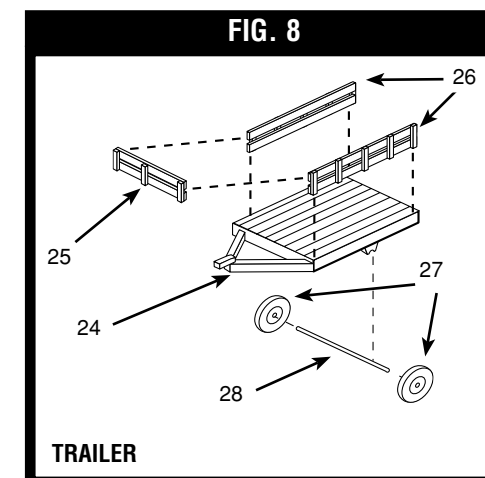

TRAILER

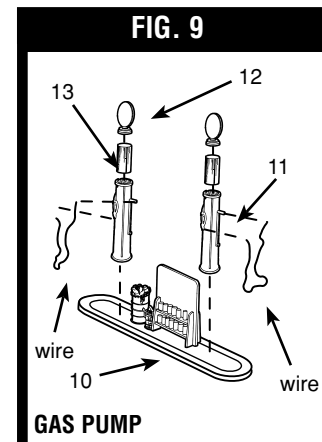

GAS PUMP

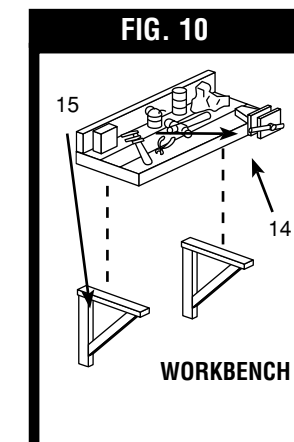

WORKBENCH

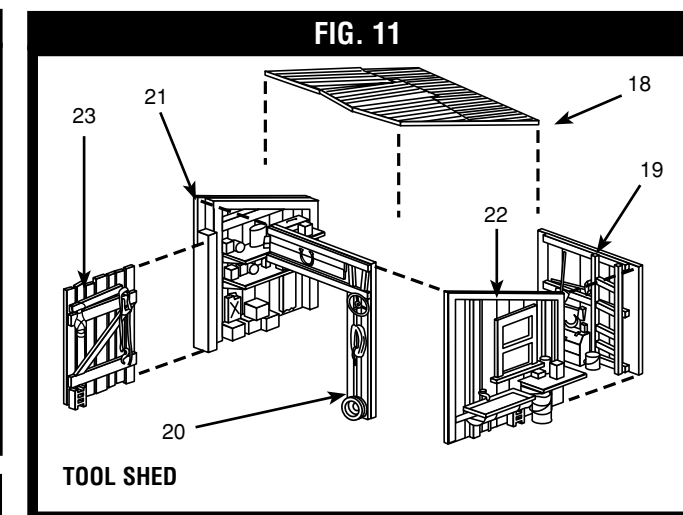

TOOL SHED

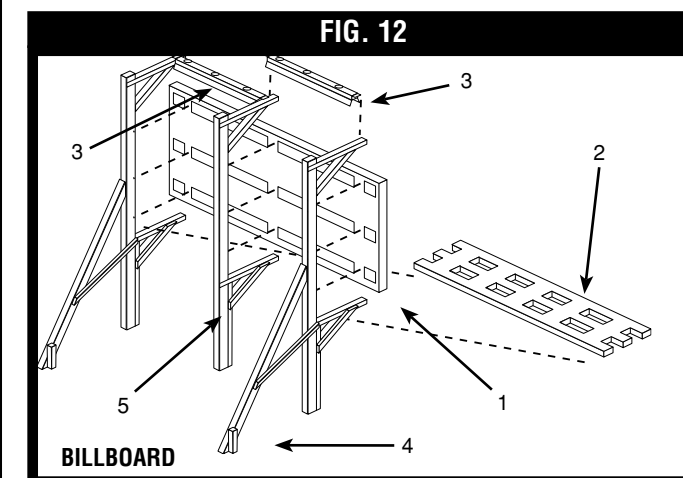

BILLBOARD

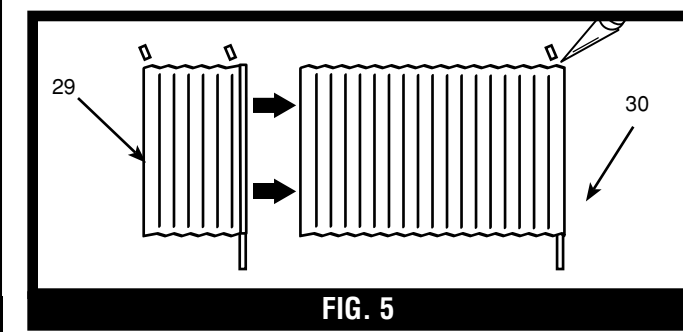

FIG. 5