

3. Black paper included in kit is for roofing material. Cut off edges as indicated in Figure B. Save all paper.
4. Starting at the bottom edge of one side of the roof, glue the first strip down. (White glue is recommended). Trim edge, see Figure C.
5. Use trimming of previous layer to start the second strip. The second strip should overlap the first by approximately 1/16". Repeat until you get to the ridge of the roof, trim any excess material over ridge.
6. Repeat steps 4 and 5 for second side.
7. Fold a roofing strip in half lengthwise for roof ridge, glue and trim. NOTE: Folding is made easier by folding strip over sharp edge.
8. Roof may be glued to structure if desired.

Mill Roof

1. Fold one piece cardstock approximately 1 1/8" down from top. See Figure B.
2. This will be your Mill Roof.
3. Repeat Steps 4 thru 8.
4. Glue Parts 31 and 32 to Part 33.
5. Glue assembly, Part 31 thru 33, to Mill Roof.
6. Glue ladder, Part 34, to roof as shown.

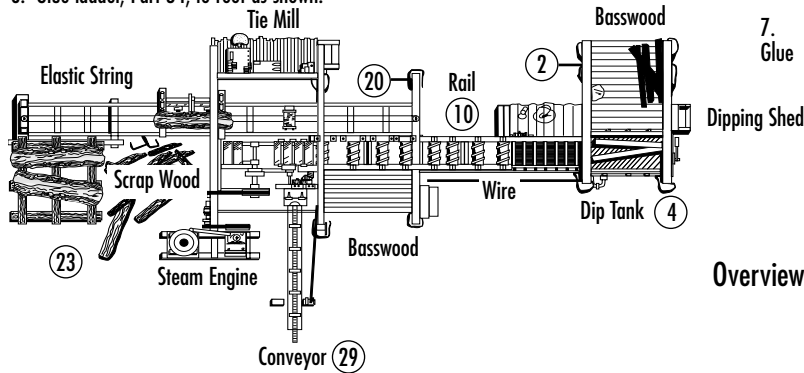

basswood section B to extended roof supports of Part 21 and 22.

FINAL INSTRUCTIONS

1. Place Mill Assembly on layout in desired position.
2. Glue Part 10 to Part 11 on Mill Assembly and Part 4 on Dipping Shed Assembly. See Figure E and Overview. NOTE: Keep track in straight line.
3. Place Steam Engine Assembly in position shown in Overview and Figure F.
4. Attach and glue power drive belt by wrapping belt around Parts 12 and 40 (power drive wheels) overlap the ends and glue.
5. Place conveyor base under Part 11 and close to Part 21 as shown in Overview. NOTE: Align pulleys.
6. Glue conveyor to layout.
7. Wrap elastic string around top pulley on Part 30 and pulley on Part 21. Glue. See Figure D.
8. Cut a piece of wire to length (approximately 2 1/2") and glue between Parts 2 and 20. NOTE: Location on Part 2 is pipe connection in branch of support beam. See Figure E location on Part 20 as shown in Figure D.
9. Glue Part 23, logway, to support of Part 15.

Ties, sawdust, cut basswood and additional castings should be used to highlight your new scene. For example: a mound of sawdust under the conveyor will show recent use.

Use your imagination, the variety of possible arrangements is what makes your particular scene unique.

Covered under one or more of the following US and Foreign patents:
US 4,202,922; US 4,278,481; US 4,082,586; UK 2,067,400

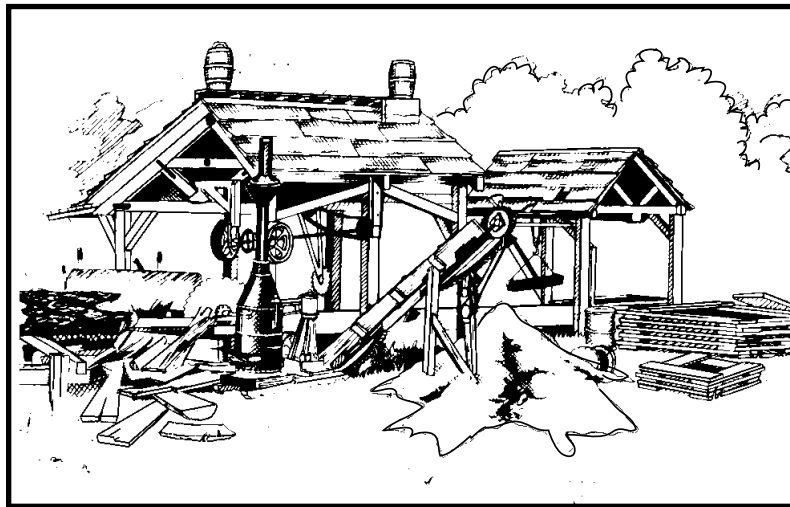

Tie & Plank Mill

TS154

INSTRUCTION INTRODUCTION

(read entire instructions before starting)

Trackside Scenes, a series of highly detailed and imaginative kits specifically designed to be easy to assemble. Please read all the instructions through carefully before starting. Should you find any pieces defective, simply return defective part to Woodland Scenics for a replacement.

A COMPLETE LANDSCAPE SYSTEM

A system that allows virtually any size or species of tree, bush, ground cover, grass, soil or weed - a system that is specially designed to work within itself - means no longer do you have to search for compatible landscaping material. Woodland Scenics offers a complete system!

OUR GROWING LINE OF QUALITY PRODUCTS

Tree Kits	Forest Kits
Foliage	Turf
Coarse Turf	Extra Coarse Turf
Foliage Clusters	Field Grass
Ballast	Ready Made Trees
Lichen	Scenic Details
Mini-Scene Kits	Landscaping Accessories

WOODLAND SCENICS BUYERS GUIDE

A fully illustrated booklet with color samples and illustrated examples of the most versatile landscape system available. Ask your local hobby shop for Woodland Scenics Buyers Guide and see the entire line of Woodland Scenics products. If not available, send \$1.85 for current Buyers Guide.

WOODLAND SCENICS®

P.O. Box 98 • Linn Creek, MO 65052

Phone 573-346-5555 • Fax 573-346-3768

www.woodlandscenics.com

©1999 OCO

Made in USA

GENERAL INSTRUCTIONS

- A. Clean-up and fit castings.** The castings in this kit will have some parting lines, flash and stems that should be removed. They can be scraped off with a knife, filed off, or sanded. If castings don't align properly, fit them by removing metal with knife or file, as required. Except for trees, the metal castings are somewhat brittle and should be handled carefully. If castings are bent or warped, straighten by placing on flat table and pushing down in high areas. All castings should be washed in soapy water and rinsed prior to gluing or painting.
- B. Gluing of castings.** Castings can be glued together with white glue, fast setting epoxy or a cyanoacrylate such as "super glue". (We prefer "super glue" because it is faster setting.)
- C. Paint castings.** We recommend that you finish your kit with Woodland Scenics Mini-Scene Paint Set (M125), our paint set includes detailed instructions on painting and weathering. Other high quality flat hobby paints will work. Plan ahead, it is often easier to pre-paint certain castings. If you pre-paint castings scrape paint from glue joints, prior to assembly.

APPLICATION OF BASE TURF

1. Locate exact position for model on your layout or mounting board. If area is glossy or slick, lightly sand. If it is covered by grass mat, remove mat and lightly sand exposed area.
2. Use varnish or white glue mix (white glue mix is prepared by diluting white glue 10-20% with water and adding a few drops of liquid detergent). Brush varnish or white glue mix on entire area. Sprinkle turf material into wet glue or varnish until completely covered. Allow to dry.
3. Brush with a soft brush or gently blow excess turf material onto a piece of paper and save.
4. Blend or mix colors of turf material until it looks natural, (one area of only one color seldom occurs in nature). If additional blending is needed, spray clear hair spray, lacquer or varnish onto desired area and apply more turf. Make sure to blend turf material of this kit with surrounding areas of existing scenes. Feather or blend all edges together with edges of existing layout.
5. If you do get too much of one color in any particular area use "spray" technique mentioned in step 4. Also, it may be desired to leave some areas "bold" (with "dirt" showing) to show wear or activity.
6. When desired coloration is accomplished, lightly spray entire surface area (step 4) to further secure.

TREE CONSTRUCTION

Preparing the Tree Armature

1. Remove any possible "flashing" from tree. Wash trees with soap and water, let dry.
2. Bend tree to a realistic three dimensional shape. For more variety, cut or break some branches.
3. Brush or spray paint tree with any flat lacquer, enamel or acrylic paint. (For acrylic paints you must first use a primer.)
4. Most trees are dark with light or medium brown highlights. After paint dries, lightly dry brush lighter or darker color for even more realism.

Application of Foliage

1. Stretch foliage material to desired density, cut material in places to create open areas (if desired).
2. Place stretched foliage material on branches of tree. If you do not obtain full coverage, stretch foliage even more. Glue to branches if desired.
3. Trim unwanted strands of foliage material with scissors. (Spray tree lightly with clear spray, hair spray, varnish, lacquer, or acrylic one last time to set foliage.)
4. Extra foliage material may be used as bushes or weeds.

NOTE: Be creative, the possibilities are endless!

KIT COMPONENTS

Instructions
Cardstock
Scribed Basswood
50 Wooden Ties
18" Elastic String
Wire
Roofing Material

7 Trees
2 Colors Foliage
2 Colors Turf
Sawdust
Over 80 Castings Including:
Tie Mill Assembly
Dipping Shed Assembly

Steam Engine Assembly
Conveyor Assembly
Saw and Track Assembly
Lights
Logs
Barrels
Pallets

INSTRUCTION SEQUENCE

DIPPING SHED FIGURES A & B

1. Clean and fit all castings.
2. Assemble and glue Parts 1 and 2 under two Parts 3. NOTE: Parts 1 and 2 should be parallel to each other and perpendicular to Parts 3.
3. Glue Part 5 under two Parts 3 and in notches provided on top of Parts 1 and 2 as shown.
4. Glue dip tank, Part 4, to Parts 1 and 2 NOTE: End with block goes toward mill as seen in Figure E.
5. Cut basswood sheet in half as shown in Figure B. NOTE: Use x-acto knife or razor blade and ruler.
6. Cut individual pieces by counting designated number of strips as shown in Figure B. Label reverse side for future reference.
7. Cut plank sections into individual strips.
8. Trim basswood floor A to size and glue to parts 1 and 2. NOTE: Front edge should fit snug to raised lip as shown. You may need to cut basswood into two pieces to install. If so, cut along scribed line.
9. Glue Parts 6 and 7 to shed assembly.
10. Using approximately 1 inch of wire, make cable for hooks on Part 8 and glue. Allow to dry.
11. Glue Part 37 into slot of Part 5. Allow to dry. Hang Part 8 from hook of Part 37.
12. Cut wire appropriate length and glue to Parts 2 and 4.

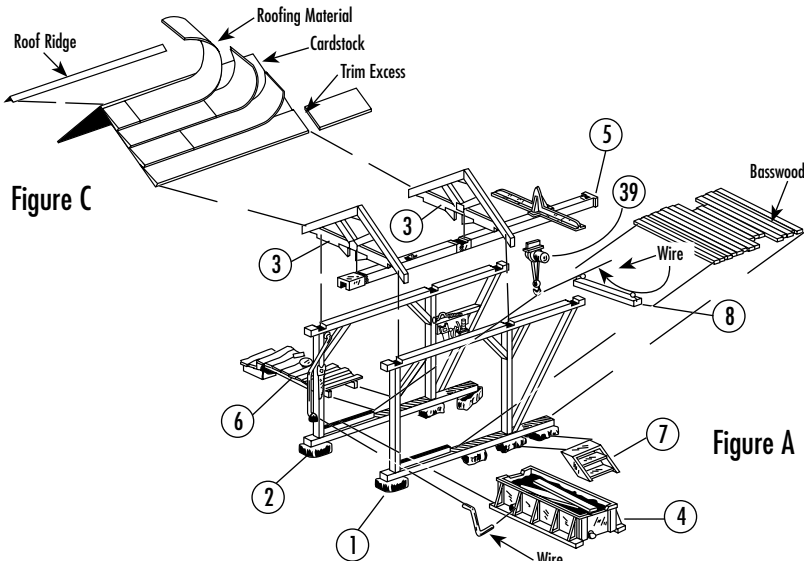

Figure B

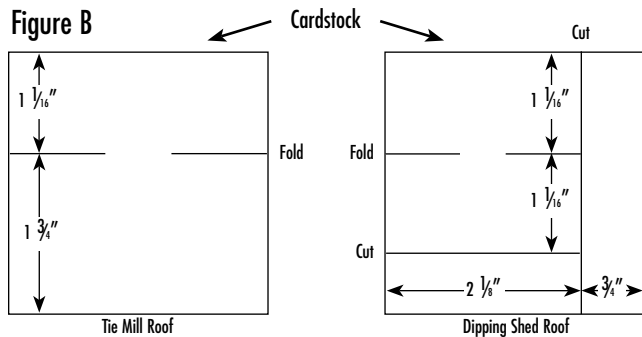
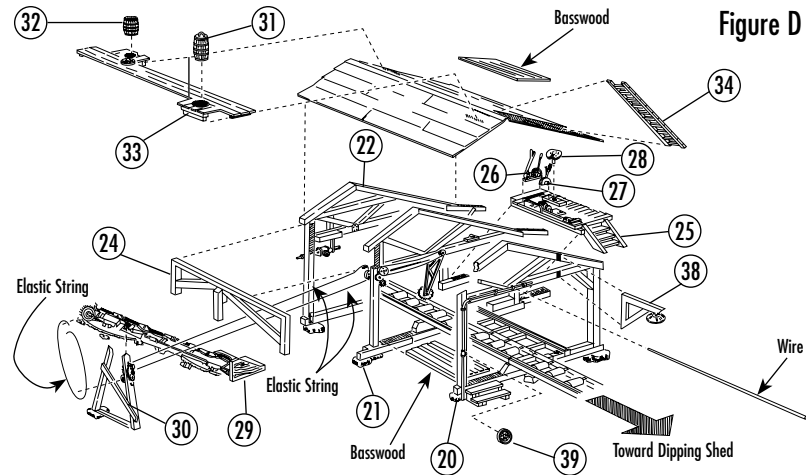
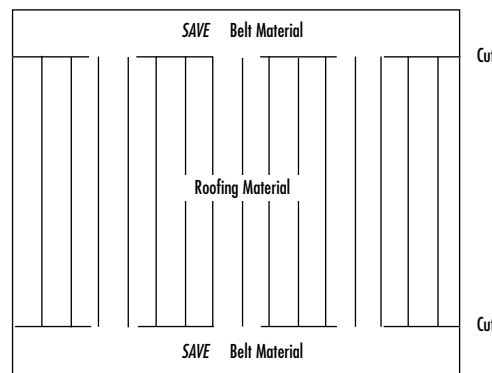
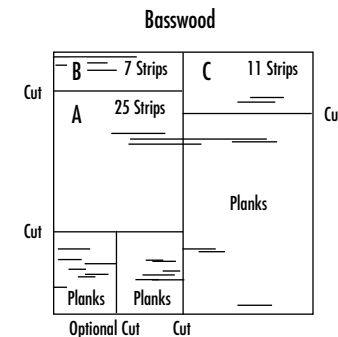

Figure A



SAW MILL ASSEMBLY FIGURES D, E & F

1. Place Part 14 in slots of Parts 20 thru 22 and glue. NOTE: Keep Parts 20 thru 22 parallel. See Figure E.
2. Glue Part 24 into notch in Part 21 and glue ends of Part 24 between Parts 20 and 22.
3. Glue Part 40 (1/4" gear) and Part 13 to Part 11. Holes in Parts 40 and 13 may need to be reamed to accept shaft. Place Part 13 directly against Part 11. Wrap elastic string around pulleys and glue.
4. Place assembly (Parts 11, 40, 13) on Parts 20 thru 22 as shown and glue.
5. Glue Part 25 to Parts 21 and 22 as shown in Figure D and overview.
6. Glue Parts 26, 27 and 28 to Part 25 in numerical sequence.
7. Cut wire approximately 1 1/4" and glue to Parts 21 and 22.
8. Glue basswood section C to Parts 20 and 21 as shown
9. Glue Part 15 to Part 14, keep track straight.
10. If desired, attach elastic string to rail by gluing string to cable drum, around end pulley of Part 14 to pulley at end of Part 15 and back to cable drum on Part 14. See Figure E.
11. Glue Part 16 to Part 15 in desired position.
12. Glue (2) Parts 17 and Part 18 to Part 16 as shown.
13. Glue cut log to Part 16 and Parts 17.
14. Glue (1) Part 39 and (1) Part 38 to Part 20 and (1) Part 38 to Part 22 as shown in Figures D & E.
15. Glue 1/4" drive wheel (Part 40) to outside shaft of Part 22. See Figure F.
16. Glue Part 12 (3/8" drive wheels) to inside shaft of Part 22. NOTE: Part 12 must line up with Part 40 of saw assembly.

Figure D

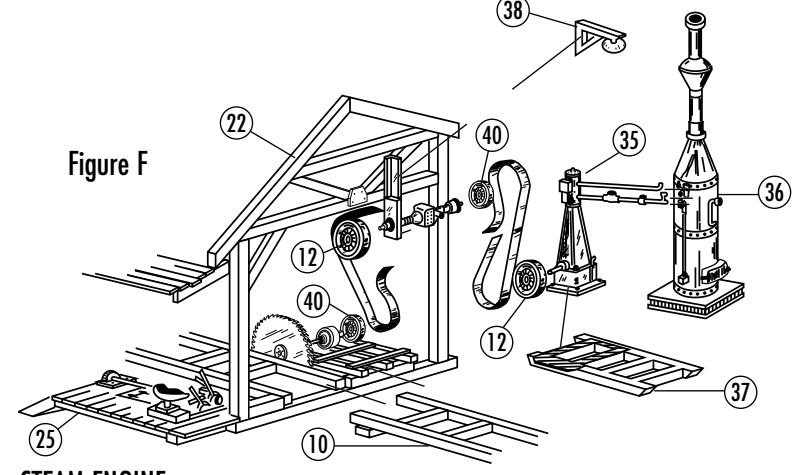

STEAM ENGINE

1. Position Parts 35 and 36 to 37 as shown. See Figure F. Note: Check to be sure pipes of Parts 35 and 36 align properly and glue Parts 35, 36 and 37 together.
2. Insert stem of Part 35 into hole on one of the 3/8" drive wheels, Part 12. NOTE: Hole may need to be reamed to fit.
3. Make a blade drive belt by cutting a strip of black paper approximately 3/32" wide and long enough to wrap around blade, both drive wheels and overlap at end. See Figure F.
4. Wrap paper strip around both drive wheels and glue.
5. Repeat step 4 for power drive belt. (Do not attach power drive belt at this time.)

CONVEYOR

1. Assemble and glue Part 30 to Part 29 as shown in Figure D. NOTE: Base should sit flat.
2. To make belt for conveyor, wrap elastic string from inside pulley of Part 30 to shaft on top of Part 29.

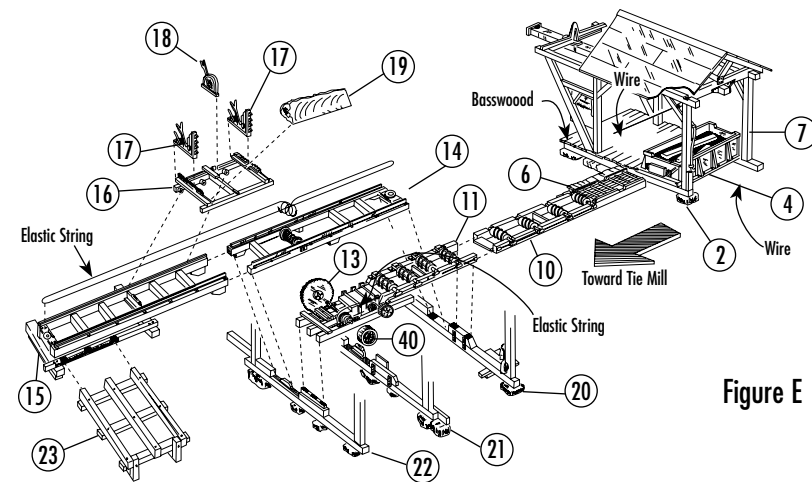

Figure E

ROOF CONSTRUCTION FIGURES B, C & D

Dipping Shed Roof

1. Cut one piece of card stock 2 1/8" x 2 1/8" as shown in Figure B.
2. Fold card stock in half. This will be your Dipping Shed Roof.