

#404 EMERY LANE INSTRUCTIONS

Follow these step-by-step instructions to construct the Emery Lane two-house set. Refer to Walls 1-7 in Step 2 to identify each building part and determine its proper location. Both houses are identical through Step 3: after that porch placement and details are different. Look through the enclosed catalog to see the complete line of DPM buildings.

404 HOUSES PARTS LIST

House Parts

Wall 1	Front door wall	2
Wall 2	One window end wall	2
Wall 3	One window back wall	2
Wall 4	Adjoining wall	2
Wall 5	Back door wall	2
Wall 6	Two window (side wall)	2
Wall 7	One window front wall	2

Roof 8	Large roof	2
Roof 9	Large roof with "V" notch ..	1
Roof 10	Small front roof	1
Roof 11	Small back roof	1
Floor 12	Front porch floor	1
Roof 13	Front porch roof	1
Floor 14	Back porch floor	1
Roof 15	Back porch roof	1

Additional Material

Clear window material - 1 (5" x 5")
 Black paper - 2 (7 3/4" x 4 1/2")
 See next page for Details Parts List.

1 Clean and prepare parts.

Use a hobby knife (i.e., X-Acto) and/or diagonal cutters (i.e., Fiskars) to remove excess plastic created by molding process, where necessary (Fig. 1A).

Tack 100-grit sandpaper to flat surface. Make sandpaper longer than longest wall. Use squaring block to keep edges square and panels flat (Fig. 1B). Move the wall panel along the squaring block.

Do not cut or sand into detail.

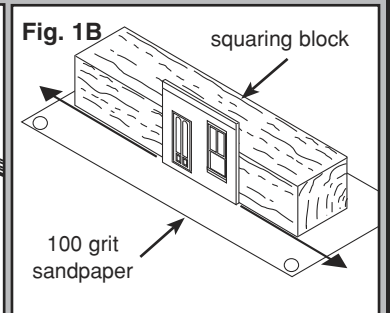
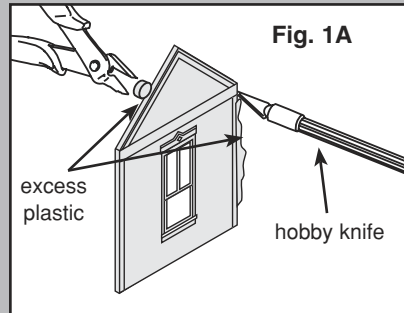

2 Assemble houses by gluing walls together.

NOTE: Both houses are identical through Step 3. Porch placement and details are different.

Work on a flat surface and use a squaring block to hold walls square while assembling.

Butt ends of Walls 4 and 6 (Fig. 2A) to back of Wall 5. Glue in place. Glue back of Wall 7 to ends of Wall 4 and 6.

Butt back of Wall 2 to ends of Walls 1 and 3 (Fig. 2B). Glue in place. Glue Walls 1 and 3 in grooves in Wall 4.

Fig. 2A

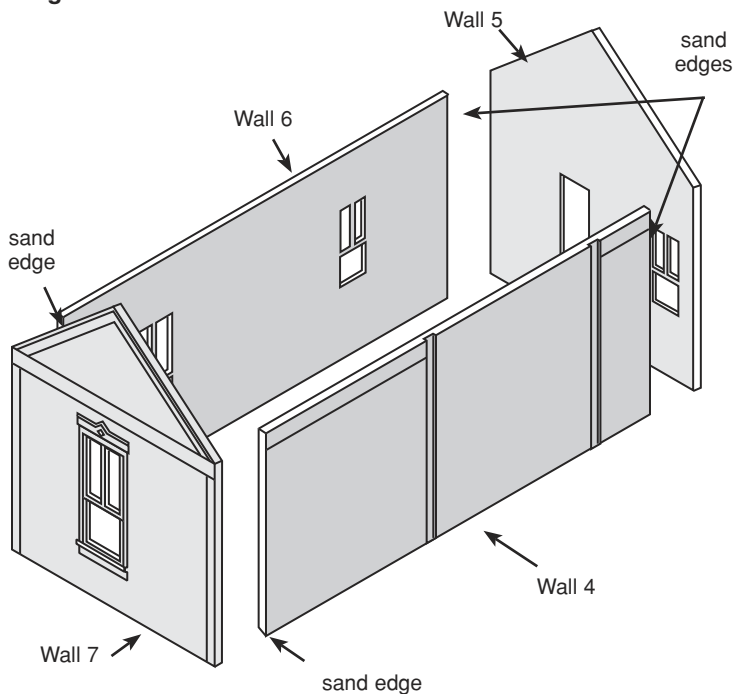
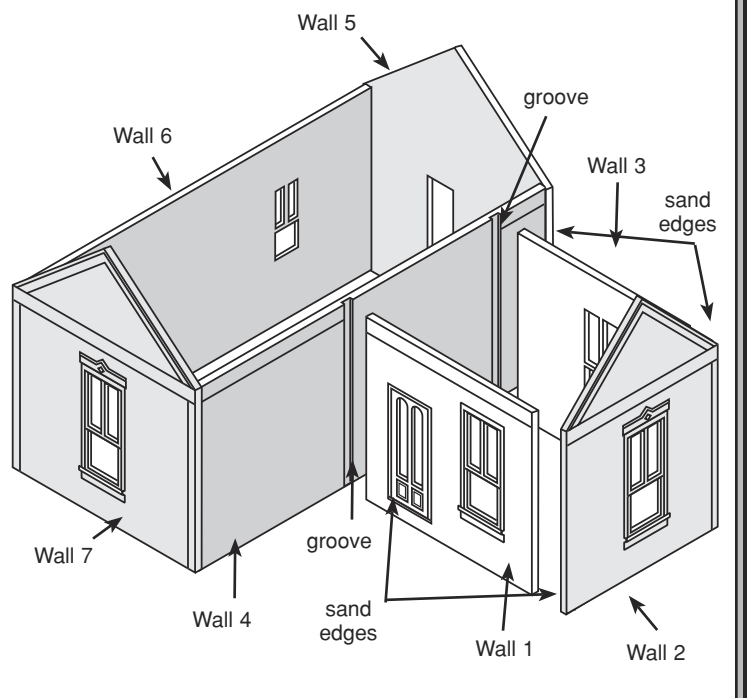

Fig. 2B



Paint building.

We recommend that you paint all building parts for the most realistic appearance. See the Painting section (under Finishing Touches) for helpful hints.

NOTE: When attaching details to building, clean paint from surfaces to be glued. Touch up paint if needed.

3 Test fit and glue roof parts together and attach to

house.

Glue Roof Parts 8 and 9 together at peak, making certain that they lay flat on top of house walls (Fig. 3A).

Glue Roof Parts 10 and 11 together (Fig. 3A) and test fit in the "V" groove in Roof Part 9. Glue in place.

NOTE: We recommend you paint house and roof parts before attaching roof. Front and rear porch parts should be attached to house before painting (see Step 4).

Position roof on walls and glue in place (Fig. 3B).

NOTE: After assembling house, sand bottom edge of walls using a circular motion.

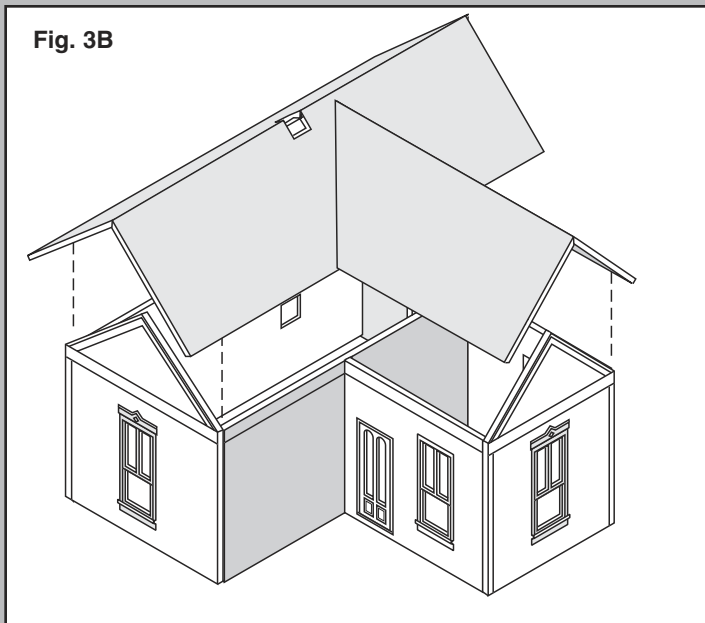
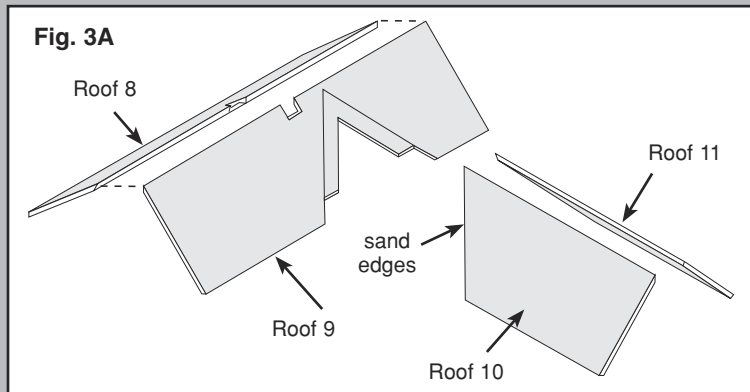

4 Attach front and back porches.

HOUSE 1

To attach front porch floor, glue Floor 12 flush with bottom of Wall 1 and Wall 4 (Fig. 4A). Use a porch post as a guide to position Roof 13 and glue to Walls 1 and 4.

For back porch glue Floor 14 centered below door and Roof 15 centered above door on Wall 5 (Fig. 4B).

HOUSE 2

To attach front porch roof and floor, glue Floor 12 and Roof 13 to Wall 5 (Fig. 4D).

For the back porch glue Floor 14 and Roof 15 to Wall 1 (Fig. 4C).

NOTE: We recommend gluing back porch brackets (Part 25) to the bottom of back porch roof (Part 15) before gluing to house. Porch railings, chimney and other details will be added later in the Details section.

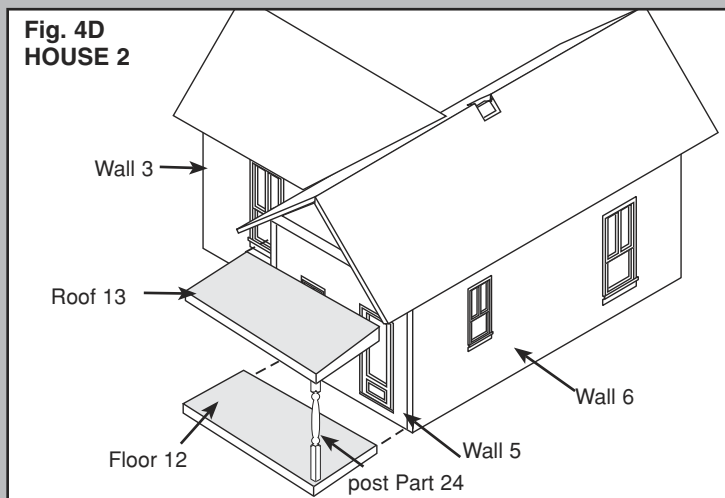
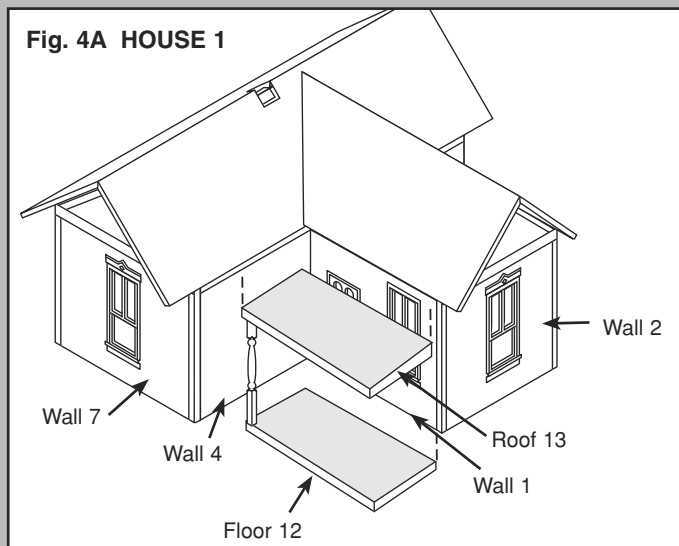
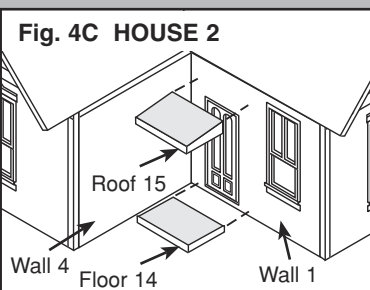
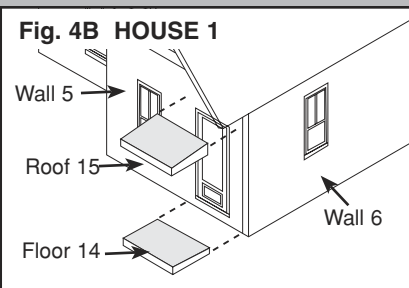

5 Finish installing details.

To complete the front porch on House 1, place first porch post (Part 24) on the open corner of the porch between roof (Part 13) and floor (Part 12) and glue in place (Fig. 5A). On front of porch, glue one full length of porch cornice (Part 23) to first porch post and roof. Glue second post to open end of cornice between roof and floor. Trim porch railing (Part 22) to fit between first and second post and glue in place. Place one post on Wall 4 and another on Wall 1 between roof and floor, glue in place. Trim two remaining cornice pieces to fit between posts, then glue in place. Trim second railing to fit between posts on side of porch. Glue in place.

On House 2, place a porch post (Part 24) on each of the two open corners of the porch between roof (Part 13) and floor (Part 12) and glue in place (Fig. 5B).

Using Fig. 5C and 5D and the picture on the box as a guide, glue Parts 22-28 to houses and Parts 3-21, 29-46 to layout.

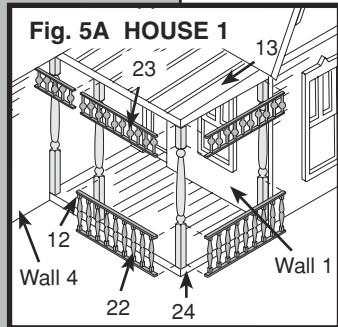

Fig. 5C FRONT VIEW

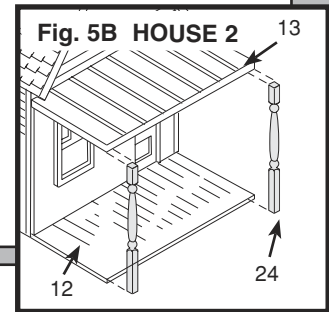
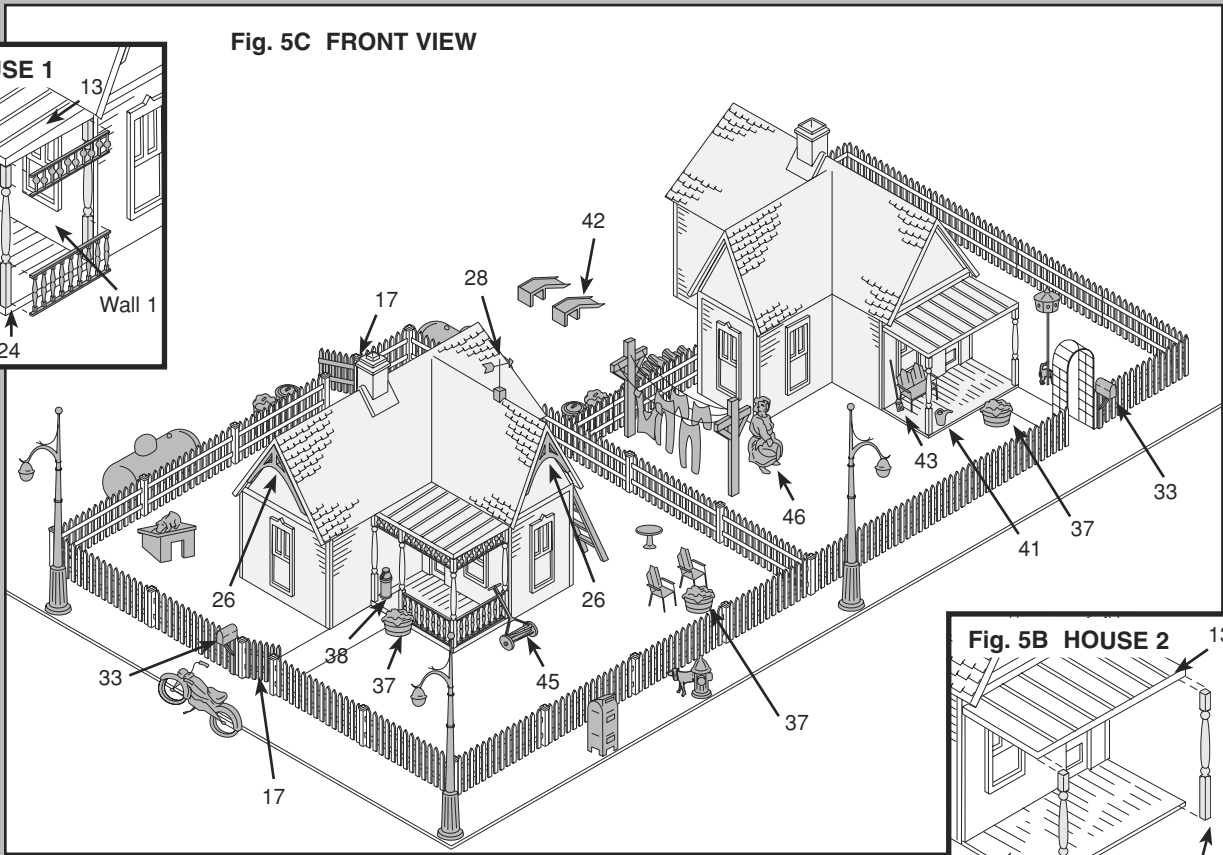
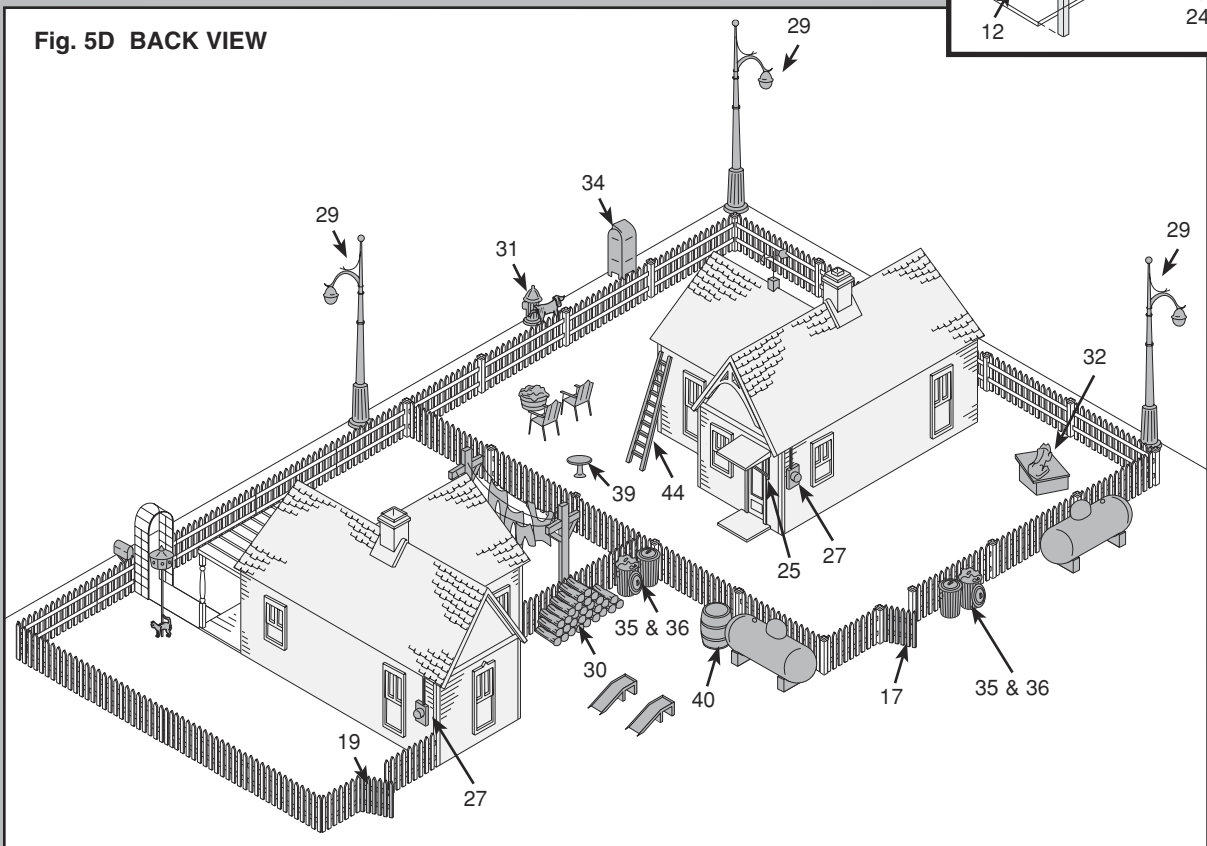

Fig. 5D BACK VIEW



ASSEMBLING DETAILS PREPARING WHITE METAL CASTINGS

Remove parting lines, flash and stems with a hobby knife (i.e., X-Acto), diagonal cutters (i.e., Fiskars), sandpaper or file. Align and fit castings. Note: Castings bend easily and should be handled carefully.

Wash all metal castings in soapy water to remove residue caused by molding process. Rinse and allow parts to dry.

Plan ahead: it is often easier to paint certain castings before assembly. We recommend using a primer coat and then painting castings with a high quality, flat paint. If you paint, scrape paint from glue points before gluing and touch up paint if necessary after assembly. See PAINTING under FINISHING TOUCHES for some helpful hints. Glue castings together with a fast-setting epoxy or a cyanoacrylate such as "super glue." We prefer a thick, gap-filling cyanoacrylate.

DETAILS PARTS LIST

The following list contains all details included with the 404 kit. Sort and organize individual detail parts. This will make assembly easier.

Part No.	Name	Qty.	Part No.	Name	Qty.
CHIMNEY	1 Chimney skirt	2	HOUSE DETAILS	22 Porch Railing	2
	2 Chimney	2		23 Porch Cornice	3
PROPANE TANK	3 Propane tank	2	24 Porch Posts	6	
	4 Base	4	25 Back Porch Bracket	4	
CLOTHESLINE	5 Posts	2	26 Gable trim	3	
	6 Pants	2	27 Power Meter	2	
	7 Underwear	2	28 Weather Vane	1	
	8 Shirt	1	MISC. DETAILS	29 Street Lights	3
LAWN BENCH AND LAWN CHAIR	9R Side (right)	3		30 Pile of Wood	1
	9L Side (left)	3		31 Fire Hydrant with Dog	1
10 Bench seat	1	32 Dog House with Dog on Top		1	
11 Chair seat	2	33 Mailbox		2	
TRELLIS	12 Trellis top	1		34 US Postal Dropbox	1
	13 Trellis sides	2		35 Trash Can with Lid On	2
MOTORCYCLE	14 Motorcycle	1		36 Trash Can with Lid Off	2
	15 Handlebars	1		37 Flower Barrels	3
FENCE	16 Post fence	18		38 Milk Jug	1
	17 Post gate	2	39 Bird Bath	1	
	18 No post fence	12	40 Barrel	1	
	19 No post gate	1	41 Watering Can	1	
BIRD HOUSE	20 House	1	42 Set of Car Ramps	1	
	21 Pole with Cat	1	43 Broom	1	
			44 Ladder	1	
			45 Lawn Mower	1	
			46 Lady Holding Basket	1	

1 Assemble chimney and propane tank.

CHIMNEY: Position skirt (Part 1) over chimney opening in peak of roof and bend down (Fig. 1A) to shape. Glue in place. Insert chimney (Part 2) and glue (Fig. 1B).

PROPANE TANK: Glue tank (Part 3) to base (Part 4) as shown (Fig. 1C).

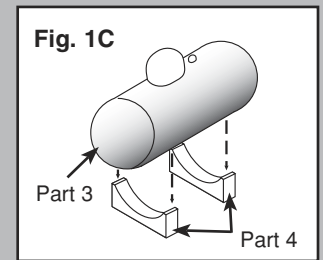
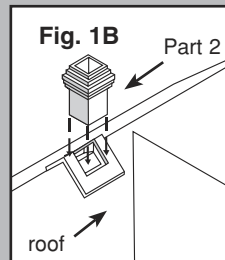
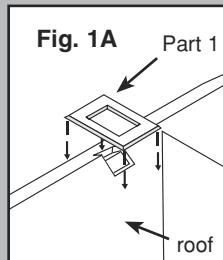

2 Assemble clothesline and lawn bench and chairs.

CLOTHESLINE: Drill two 1/8" holes in base 1 1/2" apart and place posts (Part 5) in holes covering the pins. Face posts toward each other and glue two equal lengths of wire to each side of crossbar (Fig. 2A). Allow to dry. Glue painted clothes (Parts 6-8) to wires as shown.

LAWN CHAIR AND LAWN BENCH: Glue right and left arms (Parts 9R & 9L) to the seat/back of the chair (Part 11) and the bench (Part 10).

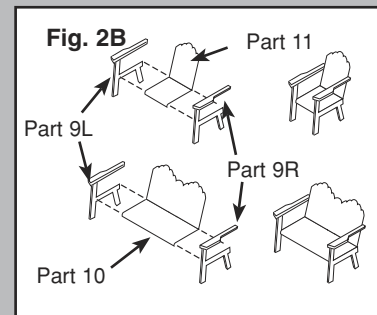
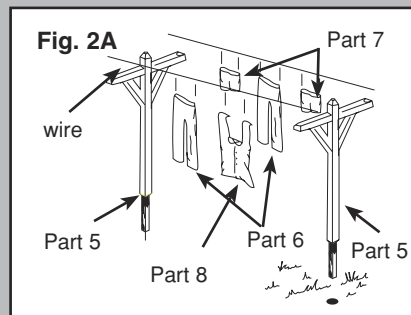

3 Assemble trellis and motorcycle.

TRELLIS: Wrap top piece (Part 12) around a 1/2" diameter pen or dowel and bend to form an arch (Fig. 3A). Trim feet of arch so space between horizontal boards is equal. Position arch (Part 12) on top of trellis sides (Part 13) and glue.

MOTORCYCLE: Glue handlebars (Part 15) to front yoke of motorcycle (Part 14) as shown.

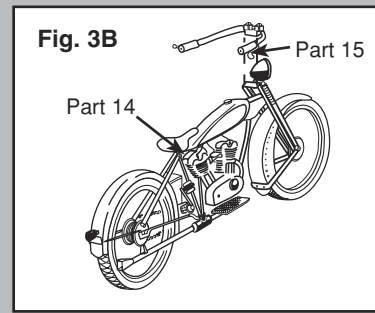
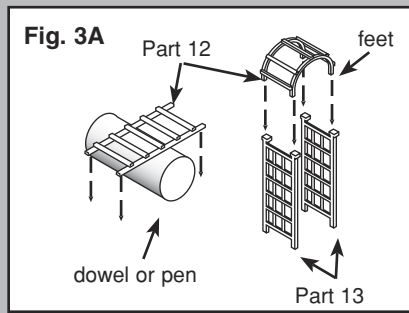

4 Assemble fence and birdhouse.

FENCE: Separate fence pieces into two groups; with post and without post. For straight run on both post (Part 16) and no post (Part 18) fence, trim half of extending rails and glue to next section (Fig. 4A).

On corners of both styles of fence trim all extending rails before gluing at 90° angle (Fig. 4B).

Glue fence to layout as shown in Fig. 5A and Fig. 5B, or where desired.

BIRDHOUSE: Glue birdhouse (Part 20) to top of pole (Part 21) as shown (Fig. 4C).

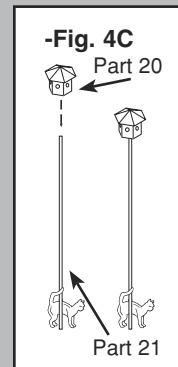
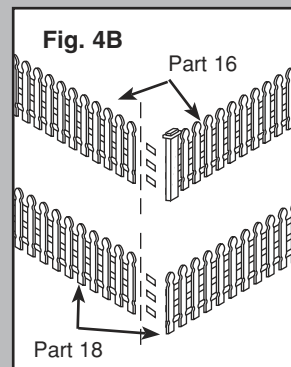
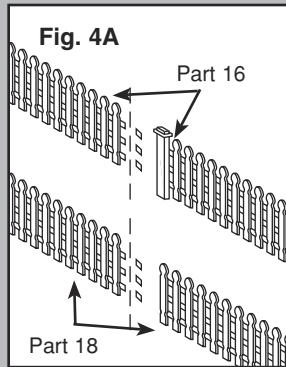

FINISHING TOUCHES

PAINTING

The appearance of the houses is enhanced by painting. We recommend airbrushing with solvent-based enamel paints, such as Floquil, in a flat finish. Use water-soluble flat paint such as Polly "S" for brushing (color is your choice). The color of the window and door frames can match or contrast with the building. The house may be aged with chalks or lightly misted by airbrushing with thinned flat black paint, such as Floquil "Grimy Black." Small details, painted a contrasting color, will add realism and enhance the buildings appearance. See the picture on the box for painting ideas. Scrape paint from glue points as necessary.

OPTIONAL IDEA

To complete the illusion that houses are occupied, place black paper (included in this kit) diagonally from corner-to-corner inside buildings to block light from entering. Masking tape, placed on inside surface of windows at various heights from top of the windows, simulates window shades.

Design Preservation Models® is a division of:

Woodland Scenics®

P.O. Box 98 • Linn Creek, MO 65052

www.woodlandscenics.com • www.dpmkits.com

MADE IN USA Z12 ©1998 DPM XINST404