

Building Parts Included in Kit

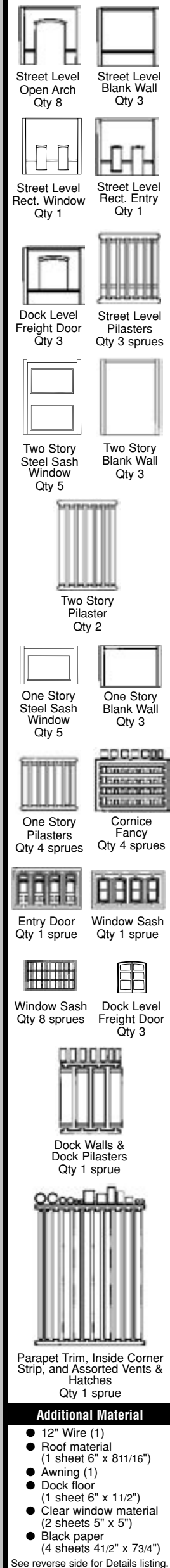

402 WHITewater BREWING INSTRUCTIONS

Follow these step-by-step instructions to construct the Whitewater Brewing building. Refer to Walls 1-7, Tunnel Walls 8-11, and to the Front, Back and Arched Tunnel Area Views illustrated below to determine the proper location for each building part. The building parts included in this kit are identified on the left. Read through instructions before constructing your building. Match the letters on the drawings below to determine where walls join. For example: [Wall 1, edge A] and [Wall 7, edge A] join each other as an "outside" corner (see Front and Back Views). [Wall 5, edge J] and [Wall 6, edge J] join each other as an "inside" corner (see Front View).

You will have some entry doors, windows, pilasters, cornices, dock wall and parapet trim left over when your building is completed.

Look through the enclosed catalog to see the complete line of DPM HO scale buildings, as well as the wall sections that are interchangeable with or can be added to this building.

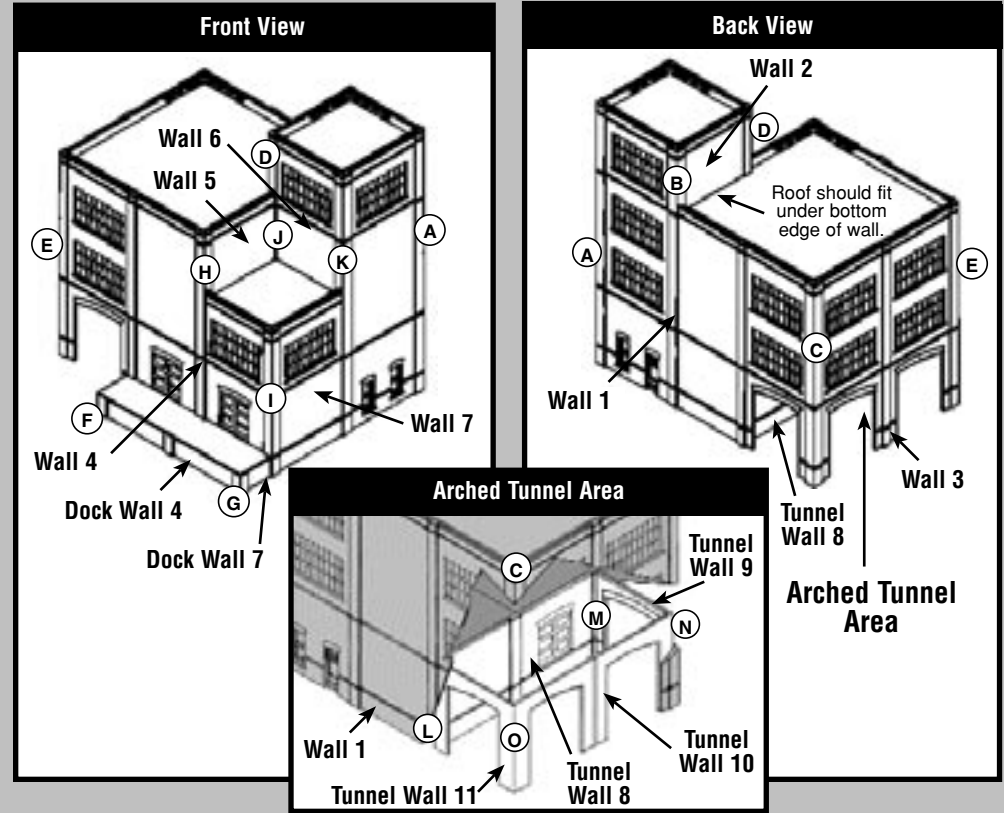
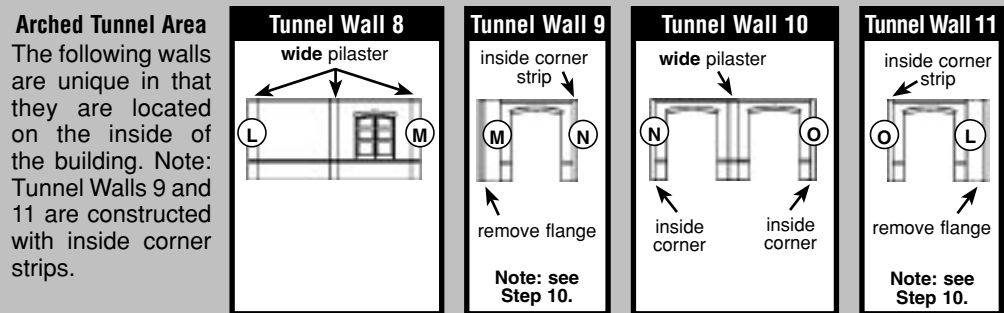
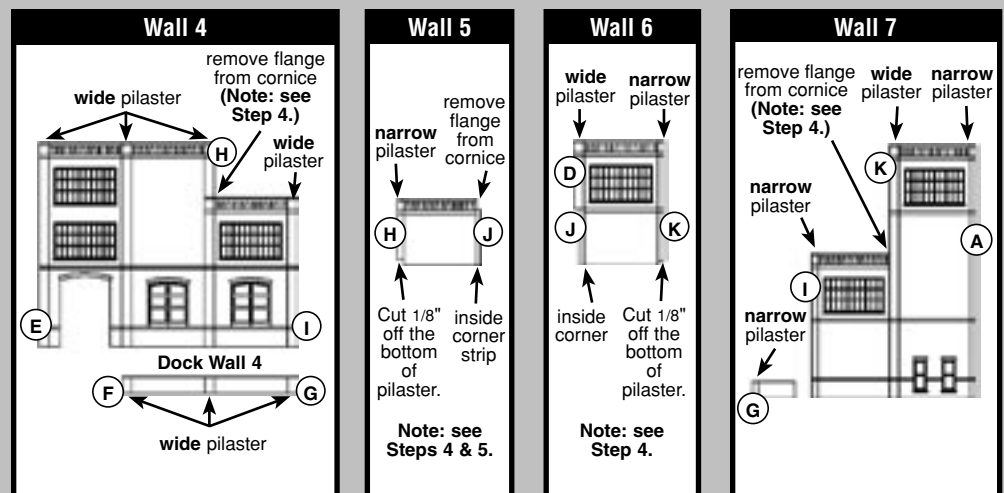
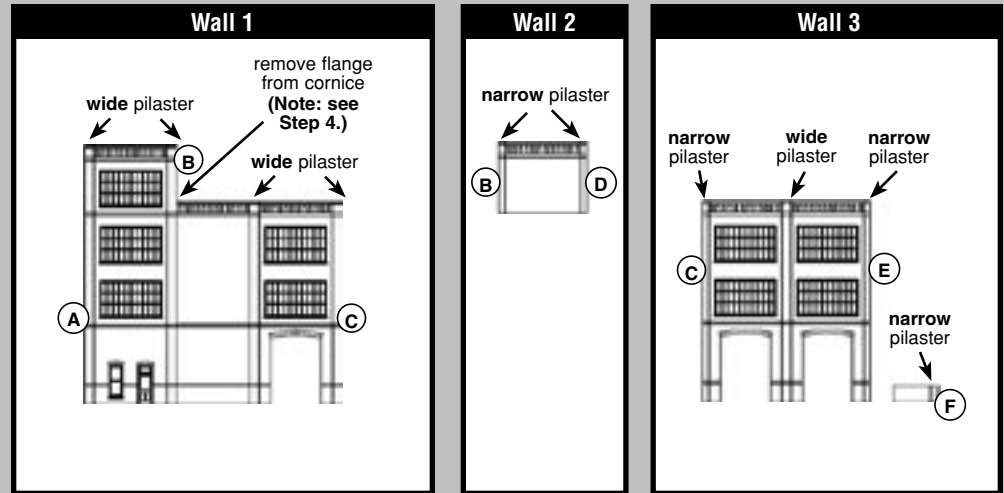

- Additional Material**
- 12" Wire (1)
 - Roof material (1 sheet 6" x 811/16")
 - Awning (1)
 - Dock floor (1 sheet 6" x 11/2")
 - Clear window material (2 sheets 5" x 5")
 - Black paper (4 sheets 41/2" x 73/4")
- See reverse side for Details listing.

1 Clean and prepare parts.

Use a hobby knife (i.e., X-Acto) and/or diagonal cutters (i.e., Fiskars) to remove excess plastic created by molding process, where necessary (Fig. 1). Don't sand any edges on parts at this time. (Later, in Step 6 you will sand tops and bottoms of assembled panels.) Do not cut into detail or alter edges of parts. Do not remove windows and door from sprue at this time.

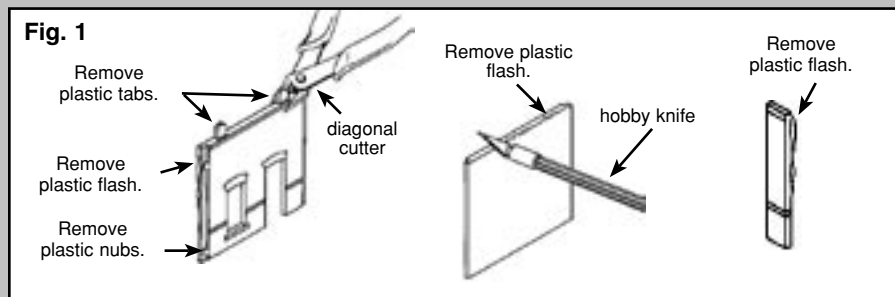

2 Identify the wall sections and pilasters needed to build each wall (see Walls 1-7 and Tunnel Walls 8 and 10) and place them in separate wall groups (Fig. 2A).

In Steps 3-6, wall sections (Fig. 2A) will be joined together side-by-side with pilasters to form wall panels (Fig. 2B). In Step 7, wall panels (Fig. 2B) will be vertically joined to form an entire wall (Fig. 2C).

Follow Steps 3-8 to build one wall at a time beginning with Wall 1. When Wall 1 is complete, repeat Steps 3-8 to build the rest of the walls, one at a time.

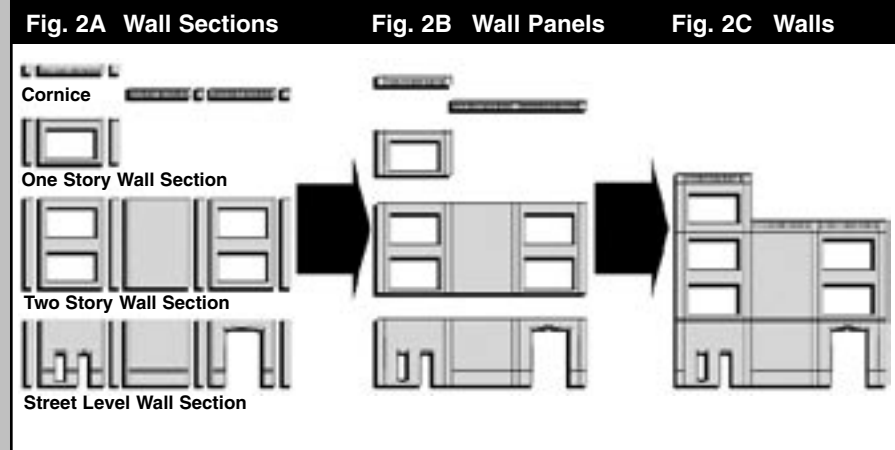

3 Using wide pilasters as joiners, glue wall sections together to form wall panels (Fig. 3A).

NOTE: Each pilaster sprue contains 5 wide pilasters (with brick detail on both sides) and 2 narrow pilasters (with brick detail on one side only). Use a straightedge to align sections at their tops (Fig. 3B), one floor at a time. Glue with plastic cement or solvent. Don't get any on detail. See Fig. 3C for right way (no gap) and wrong way (gap) to attach pilasters.

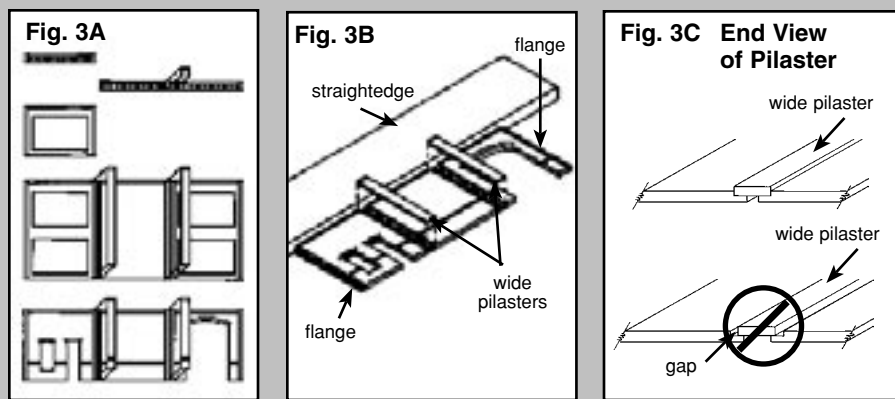

4 Glue pilasters on ends of wall panels 1-7 and Tunnel Wall 8 (Fig. 4A). Remove cornice flange (Fig. 4C).

WARNING: Correct placement of wide and narrow pilasters is critical to proper assembly of finished walls. NOTE: Step 4 does not apply to Tunnel Walls 9, 10, or 11. See Walls 1-7 and Tunnel Wall 8 to determine the wide and/or narrow pilasters each wall requires. Smooth edges on narrow pilasters face toward outside of wall, not toward wall sections (Fig. 4B). Note that wide pilasters must go on both ends of Tunnel Wall 8 also. (These will be modified in step 10.)

NOTE: Before attaching narrow pilasters to left side of wall 5 and right side of wall 6, use diagonal cutters to cut off 1/8" from bottom of these two pilasters only to allow adjacent cornices to fit properly.

NOTE: See walls 1, 4, 5, and 7 to determine where cornice flanges must be removed (Fig. 4C).

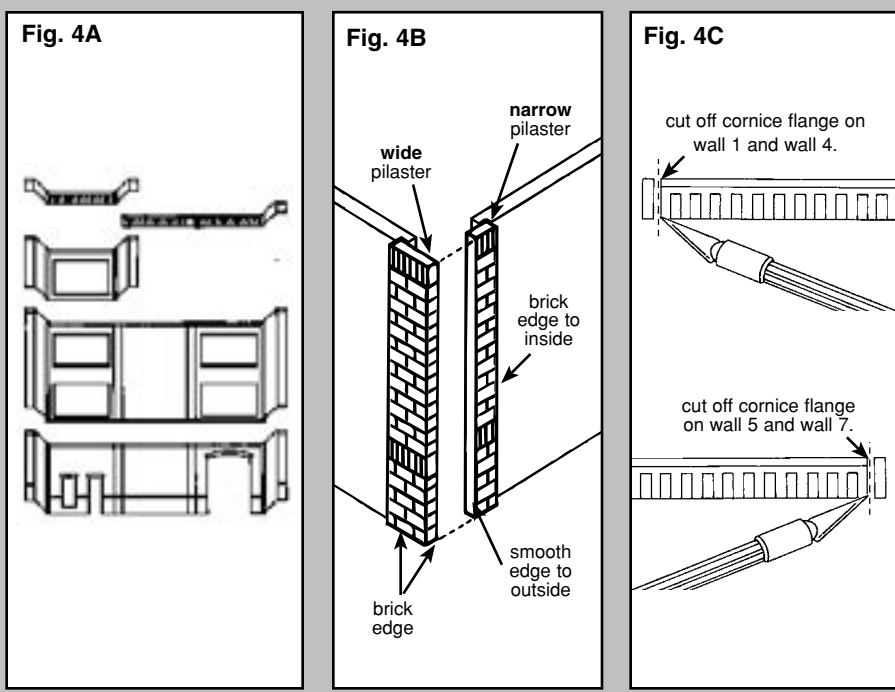

5 Glue inside corner strip to wall 5 - edge J only. Note: When building other walls, skip this step.

NOTE: Remove inside corner strips from sprue (Fig. 5B). Score and snap off a piece of an inside corner strip so it extends slightly beyond top and bottom of wall 5 (Fig. 5C). The ends of this strip will be sanded off in Step 6. Glue corner strip to flange on right side of wall 5 (Fig. 5C).

Using a squaring block as shown in Step 8A, sand flange to remove excess plastic until flange is flush with attached corner strip (Fig. 5D).

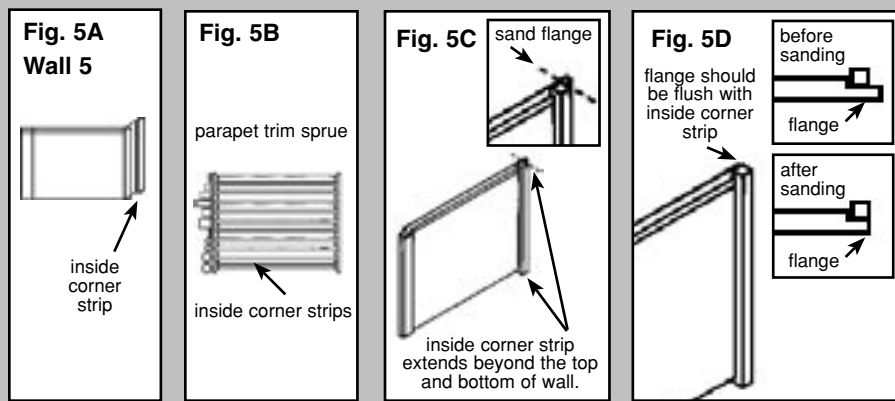

6 Sand top and bottom of each assembled wall panel to align and square up all wall section edges.

NOTE: This step is essential to achieve proper fit later. Tack 100 grit sandpaper to flat surface. Make sanding area longer than longest wall. Use squaring block to keep edges flat and hold panels square as you sand (Fig. 6B). (Move the wall panel, not the block.)

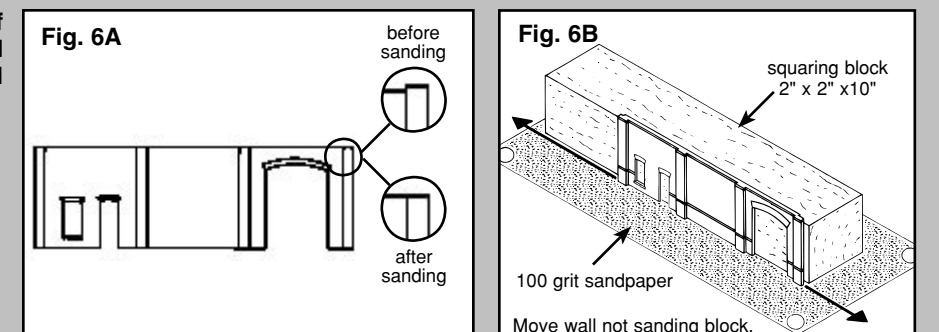

7 Glue wall panels together vertically to form entire wall.

Align pilasters (Fig. 7A) and glue wall panels together. Align pilasters and glue cornice panel to top wall panel (Fig. 7B). Entire wall is now assembled.

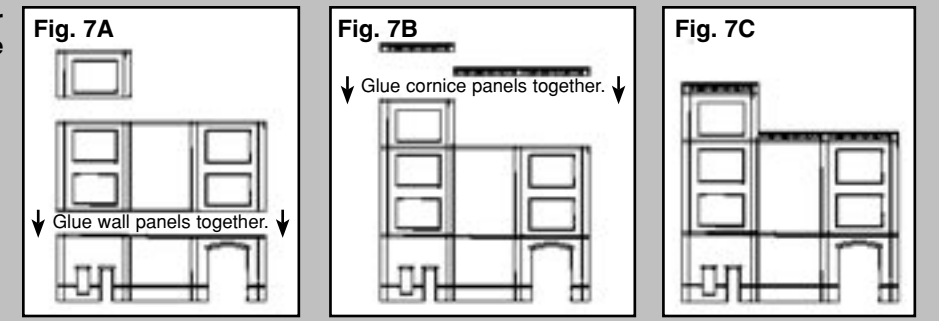

8 Sand smooth edges only of narrow pilasters just enough to square them (Fig. 8B).

NOTE: This step only applies to walls 2, 3, left side only of 5, right side only of wall 6, and wall 7. Edges of narrow pilasters must be squared so they can be aligned to fit snugly with wide pilasters in Step 9. NOTE: Do not sand edges of wide pilasters (located on front and back walls 1, 4, & left side of wall 6). To do so would remove brick detail. Repeat Steps 3-8 for remaining exterior walls until all of them are completed.

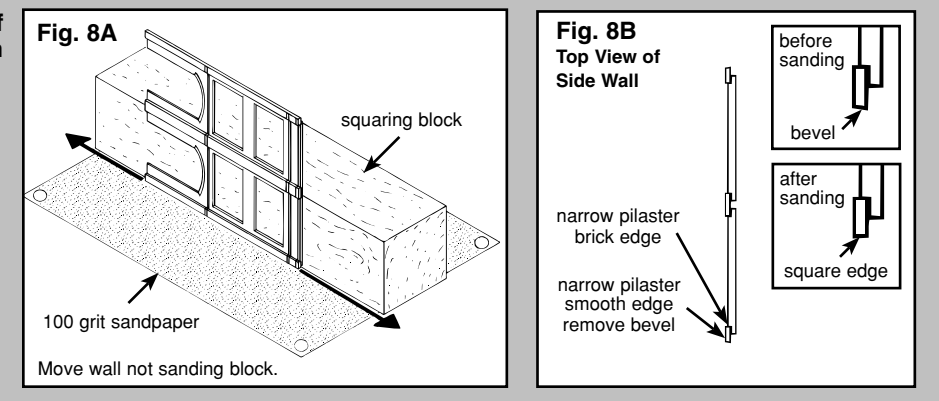

9 After all of the exterior walls are assembled, glue them together at corners.

Use a squaring block to hold all corners square while gluing (Fig. 9A). You will be butting narrow pilasters against backs of wide pilasters (Fig. 9A). Align and glue walls together in this order: Join inside corner walls (walls 5 & 6) together at installed corner strip. Glue wall 2 to wall 6 (Fig. 9B). Set this assembly aside to dry. Align and glue wall 1 to wall 3; wall 3 to wall 4; wall 4 to wall 7; wall 7 to wall 1. Then align and glue the walls 5, 6 and 2 assembly in place: Wall 2 to wall 1, wall 5 to wall 4, and wall 6 to wall 7 (Fig. 9B).

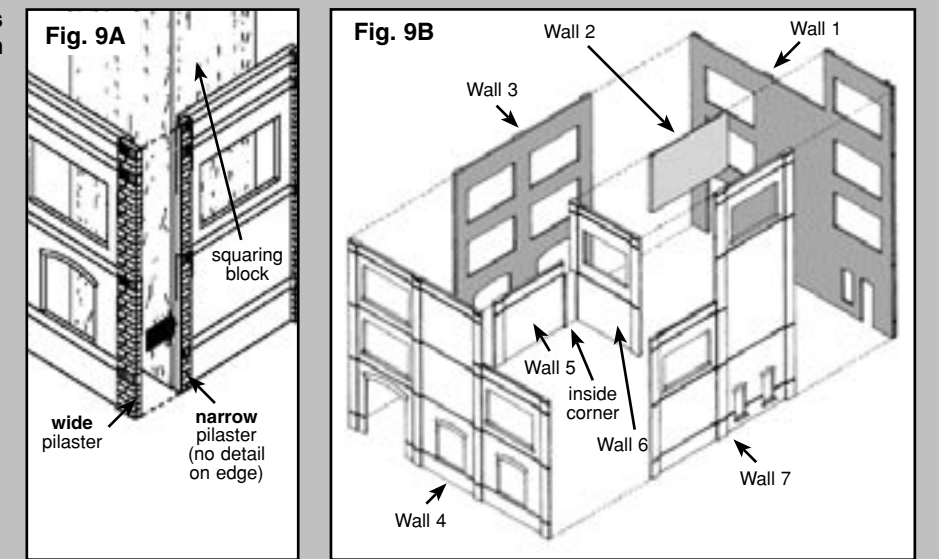

10 Assemble Tunnel Walls 9 and 11; install all Tunnel Walls (8, 9, 10, and 11).

Tunnel Walls 8 - 11 are the walls located inside the arched tunnel area shown in Arched Tunnel Area inset; they are joined somewhat differently than other walls.

NOTE: Use the inside corner strips you removed from sprue in step 5. Measure, score and snap off pieces of those strips so they extend slightly beyond tops and bottoms of right side of Tunnel Wall 9 and left side of Tunnel Wall 11. Attach corner strips to those two flanges (Fig. 10A) and allow to dry. Sand the ends of corner strips off as shown in step 6.

Align and glue Tunnel Wall 10 to back side of wall 3, Tunnel Wall 9 to back side of wall 4, and Tunnel Wall 11 to back side of wall 1 (Fig. 10B).

Measure distance between Tunnel Walls 9 and 11 where Tunnel Wall 8 with its attached pilasters will be installed. Sand and remove excess width from the pilasters on ends of Tunnel Wall 8 (see Fig. 5D). Glue pilasters on Tunnel Wall 8 to Tunnel Walls 9 and 11 (Fig. 10C).

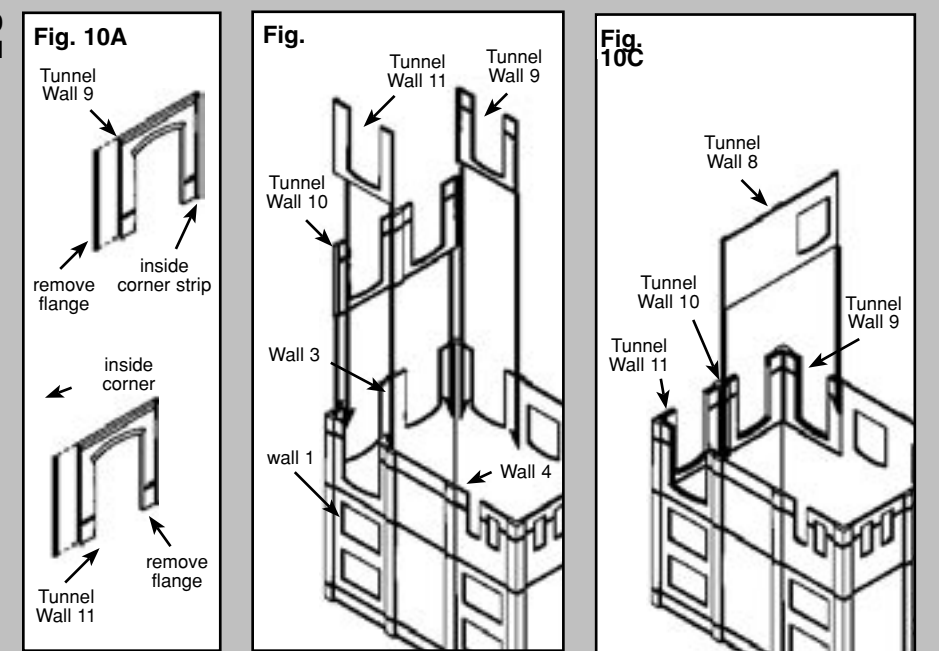

11 Transfer size of roof openings to roof material; cut out roof pieces.

Begin with the largest opening and trace it on roof material, beginning at a corner of the material (Fig. 11A). Repeat with roof opening formed by walls 1, 2, 6, and 7.

Measure roof opening formed by walls 4, 5, 6 and 7. Transfer measurements to a piece of cardboard, test fit in opening, and adjust as necessary. Trace pattern on roof material.

Cut all roofs out and test fit (Fig. 11B). Set roofs aside for now.

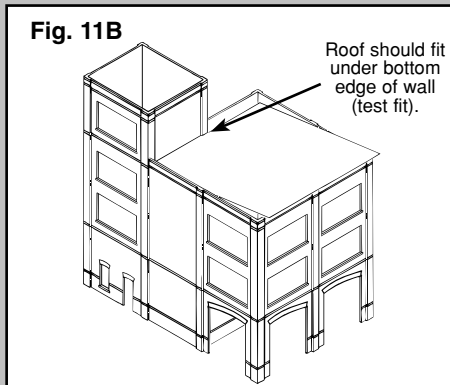
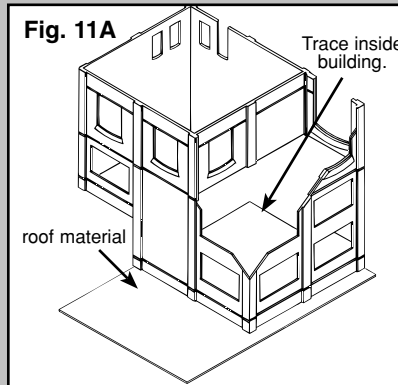

12 Fit and glue parapet trim strips.

Score, snap off, fit and sand parapet trim strips to length to fit building (Fig. 12B).

Glue in place to back side of wall and flush with top edge (Fig. 12C).

Optional: Fill voids at top of wall sections with spackle or plastic putty. Note that you will need to paint building if you fill with spackle or putty.

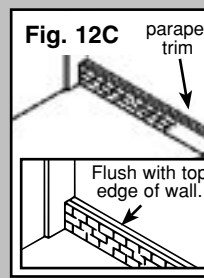
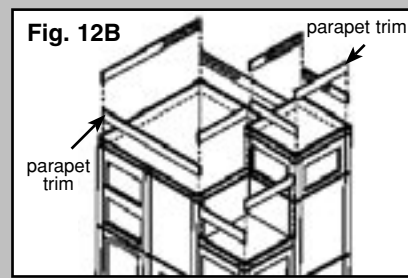
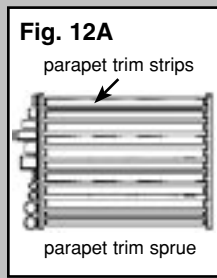

13 Assemble dock walls; notch dock floor.

Assemble dock walls in the same manner as wall panels, noting location of wide and narrow pilasters.

Note that building serves as back wall of dock. Dock floor should overlap dock walls slightly and cover tops of dock pilasters.

Cut off dock side walls evenly so they are slightly narrower than the width of the dock floor (1 1/2") (Fig. 13A).

Glue dock walls to building (Fig. 13A).

Using a hobby knife, cut dock floor to correct length (slightly overlapping dock wall). Notch dock floor to fit around building's pilasters (Fig. 13B).

Do not glue dock floor in place yet.

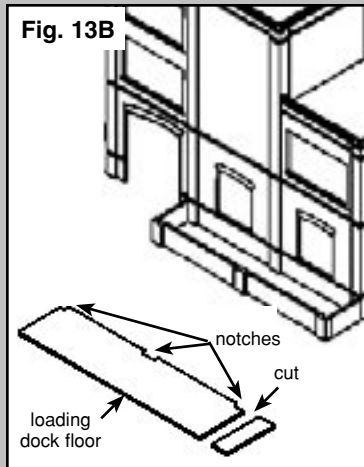
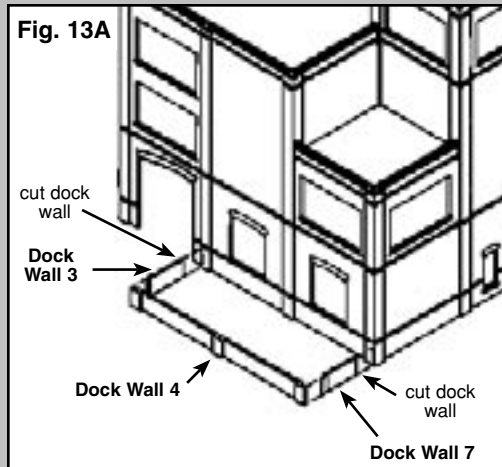

Paint building parts.

We recommend that you paint all building parts for the most realistic appearance. However it is not mandatory.

See *Painting under Finishing Touches* for helpful hints.

Doors and windows are easier to paint if left on sprues. When paint is dry, remove windows and doors from sprues.

Clean paint from surfaces to be glued. Touch up paint if needed.

14 Install roofs and dock floor.

Position roofs from inside of building. Glue roofs to bottom of parapet trim (Fig. 14A).

Glue dock floor to dock walls (Fig. 14B).

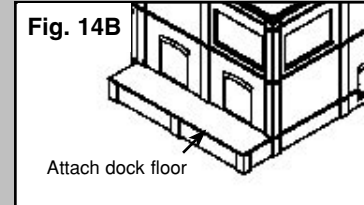
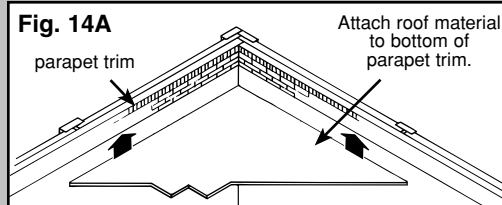

15 Glue window frames and door with window to clear window material. Install all doors and windows.

See Fig. 15A for the best way to get all windows and door with window glued on the two furnished pieces of clear window material.

When gluing frames to clear material, leave a minimum of space between each frame (Fig. 15A).

Keep glue off detail and window material that will be seen from the outside of building.

When glue is dry, cut windows and door apart.

Install windows, doors and freight doors from inside of building (Fig. 15B).

To make a roof inside the arched tunnel area, cut and fit a piece of black paper (approximately 3"x5 1/2") (included in kit) and attach to top of Tunnel Walls 8, 9, 10 and 11. Additional pieces of black paper placed diagonally from corner to corner inside building sections will complete the illusion that building is occupied. Cut black paper to fit and install it.

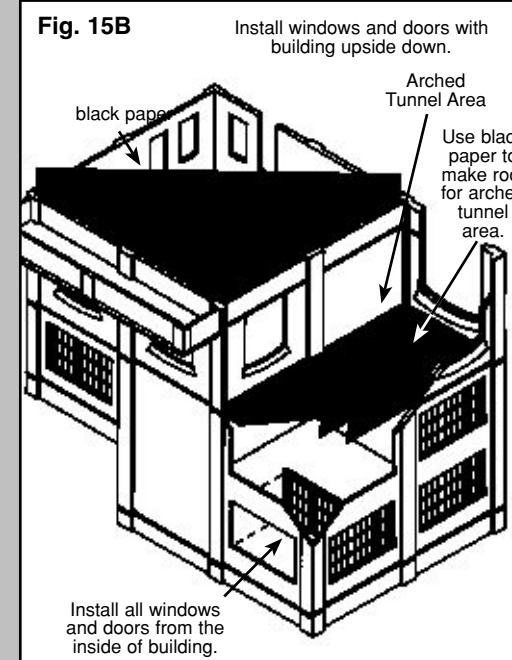
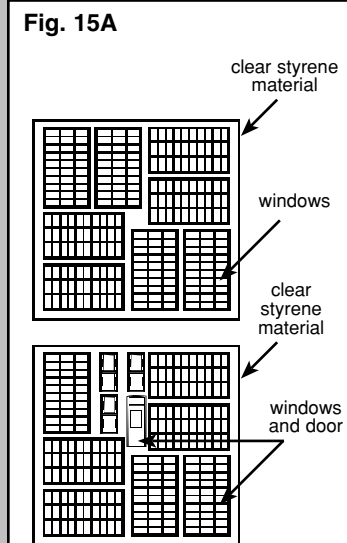

DETAILS PARTS LIST

The following list contains all details included in the 402 building. Sort and organize individual detail parts, this will make assembly easier.

No.	Name	Qty	No.	Name	Qty
SMOKESTACK					
1	Smokestack (Plastic Tube)	1	12	Lights	2
2	Smokestack Rings	1	13	"L" - Bend Wall Vent	1
STEPS					
3	Railing	1	14	Louvered Wall Vent	1
4	Steps	1	15	Wall Fan	1
MISCELLANEOUS BUILDING PARTS					
5	Ladder	2	16	Electric Meter with Conduit	1
6	Valve Wheel for "L" Pipe	1	17	Assorted Plastic Vents and Hatches	13
7	"L" Pipe	1	MISCELLANEOUS BUILDING PARTS		
8	Awning Brackets	2	18	Aluminum Kegs	8
9	Awning (styrene)	1	19	Wooden Kegs	8
10	Roof Air Conditioner	1	20	Full Crates	8
11	Roof Vents	2	21	Empty Crates	8
			22	Hand Truck	1

ASSEMBLING DETAILS PREPARING WHITE METAL CASTINGS

Remove parting lines, flash and stems with a hobby knife (i.e., X-Acto), diagonal cutters (i.e., Fiskars), sandpaper or file. Align and fit castings. Note: Castings bend easily and should be handled carefully. To straighten bent or warped castings, lay them flat on a table and push down to table top.

Wash all metal castings in soapy water to remove residue caused by molding process. Rinse and allow parts to dry.

Plan ahead; it is often easier to prepaint certain castings before assembly. We recommend using a primer coat and then painting castings with a high quality, flat paint. If you prepaint, scrape paint from glue points before gluing and touch up paint if necessary after assembly. See *PAINTING under FINISHING TOUCHES* for some helpful hints. -Glue castings together with a fast-setting epoxy or a cyanoacrylate such as "super glue." (We prefer a thick, gap-filling cyanoacrylate.)

1 Assemble the smokestack.

Sand both ends of styrene tube (Part 1) to square up. With the point of a hobby knife, slightly ream inside edge of Part 2 until it fits on Part 1 (Fig. 1A).

Cut wire into four equal pieces each 3" long. If necessary, straighten wire by placing on table top and firmly stroking along its length several times until straight. Thread (from the top) one end of a piece of wire through one of the four holes in Part 2, and bend as shown in Fig. 1B. Repeat with other three wires and holes.

Position Part 2 on Part 1 about 13/4" from top and glue in place.

Glue smokestack assembly to roof of building. Position wires and glue them to the roof where they touch (Fig. 1C).

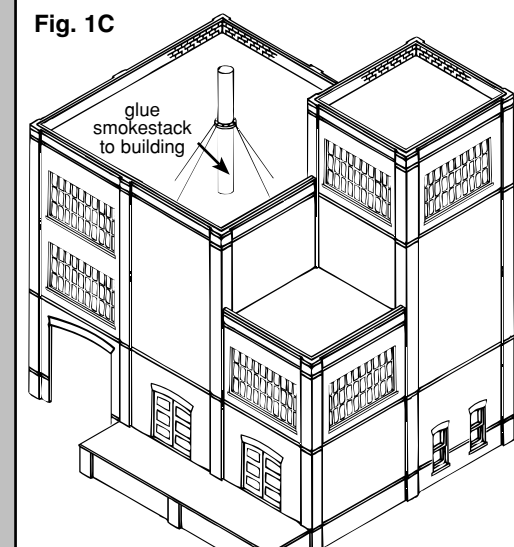
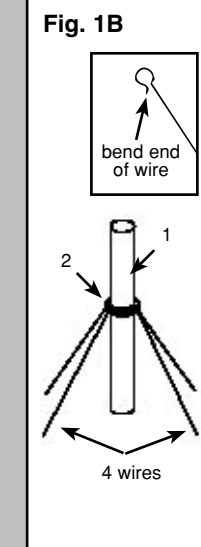
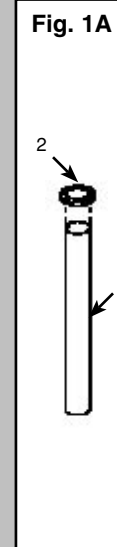

2 Prepare and install stairs.

Fit and glue Part 3 to Part 4 (Fig. 2A).

Glue stairs assembly to end of dock (Fig. 2B).

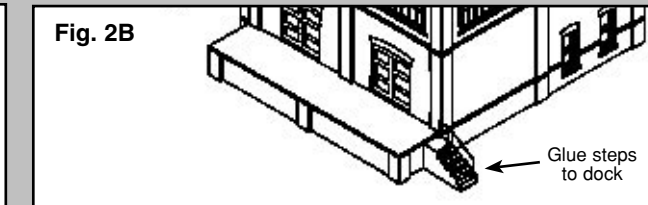
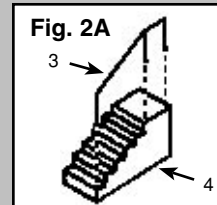

3 Prepare ladders.

NOTE: Curved handrails on ladders (two Part 5's) are optional.

To form handrails on ladders, bend end 3/8" or 1/2" around a coat hanger, sixteen penny nail or other round object with similar diameter (1/8") (Fig. 3A). IMPORTANT: Keep rails on Part 5 parallel.

After bending, carefully remove top four rungs only (Fig. 3B). Sand or file spots where rungs were attached, if necessary. Repeat with other ladder.

Shorten ladders as necessary for appearance and/or height of structure by cutting with diagonal cutters. Glue ladders to building (Fig. 3C).

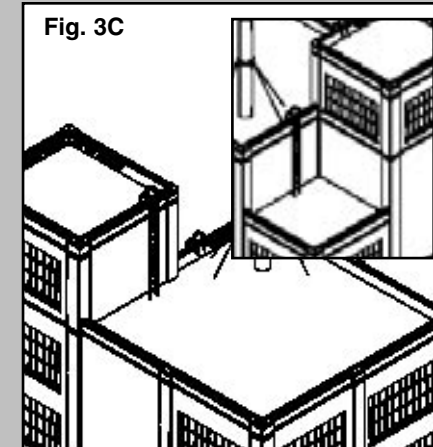
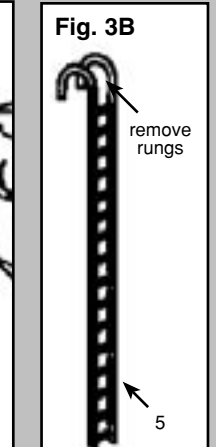

4 Assemble L-shaped pipe.

Glue center of Part 6 to stem on Part 7 (Fig. 4A).

Glue Part 7 to building (Fig. 4B).

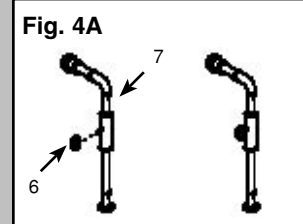

5 Prepare awnings and attach them to building.

Use hobby knife to notch one long side of awning (Part 9) at both corners to fit around pilasters (Fig. 5A).

Glue short legs of both Part 8's to building at exact same height (Fig. 5A). Glue Part 9 to Part 8's and to building (Fig. 5B).

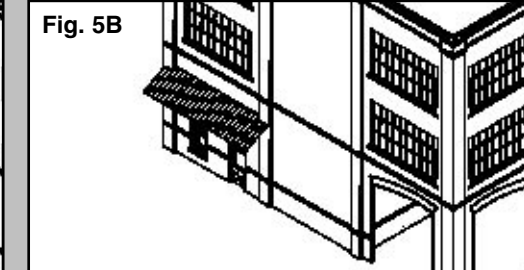
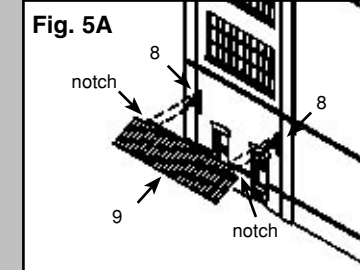

6 Attach remaining details.

Glue Parts 10-17 where shown in Fig. 6A & 6B or where desired. Note: You may want to glue a 3/4" square piece of black paper to back of wall fan (Part 15) before attaching fan to building or paint building black where fan will be attached.

Place Parts 18-22 where shown in photograph on box or where desired.

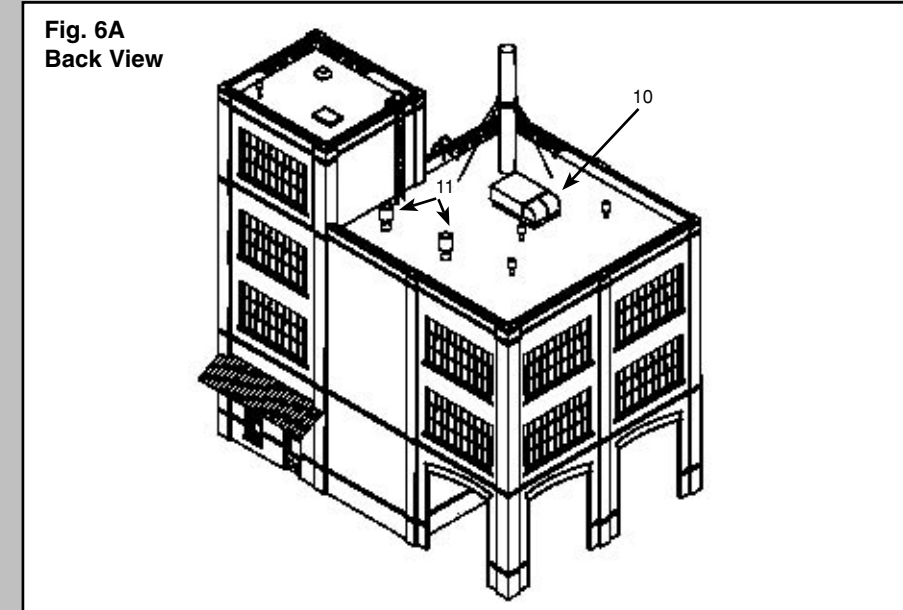
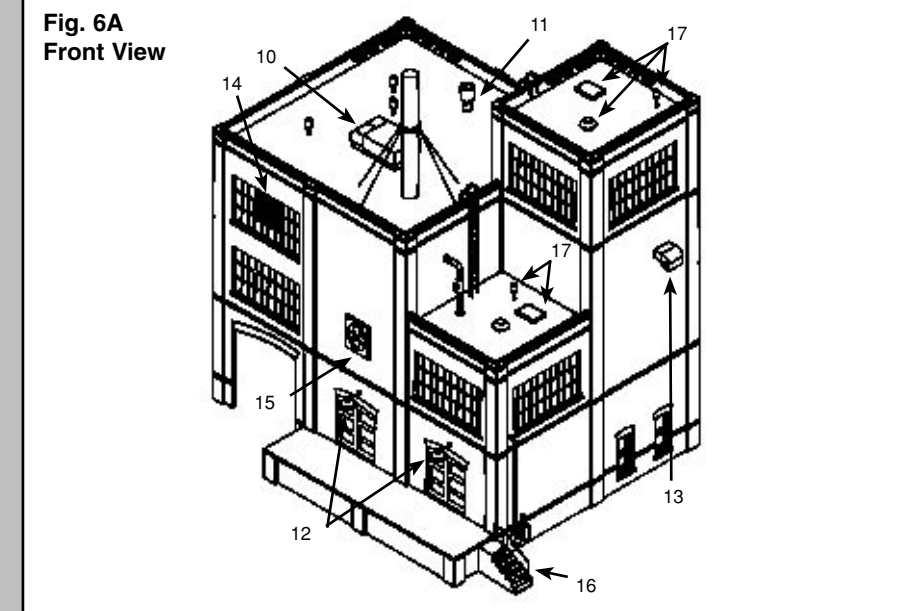

FINISHING TOUCHES

PAINTING

Appearance of buildings is enhanced by painting. We recommend airbrushing with solvent-based enamel paints, such as Floquil, in a flat finish. Use water soluble flat paint such as Polly 'S' for brushing (color is your choice). We prefer natural brick colors in earth tones for entire building and the dock walls. Other suggestions: dock floor - Floquil "Concrete," roofs - "Flat Black," smokestack - a black or gray color. Color of window and door frames can match or contrast with building. Building may be aged with chalks or lightly misted by airbrushing with thinned flat black paint such as Floquil 'Grimy Black.' Small details painted a contrasting color will add realism and enhance building's appearance. See the picture on the box for painting ideas. Scrape paint from glue points as necessary.

OPTIONAL IDEA

You may want to apply a very fine sand to the roofs to simulate a "gravel" texture.

Masking tape placed on inside surface of windows at various heights from top of the windows simulates window shades and gives the building an occupied appearance.

DRY TRANSFER DECALS

- Place a dry transfer decal in position shown in picture on front of package, or where desired.
- Hold carrier sheet gently so it cannot move while you rub over the decal with a burnisher or dull pencil.
- Carefully remove carrier sheet. If transfer was incomplete, let sheet fall back into place and transfer remainder.
- Place backing paper over decal and reburnish. Repeat with other decals.

NOTE: The cast details and Dry Transfers in this kit were made by Woodland Scenics for Design Preservation Models. See the entire line of Woodland Scenics Dry Transfers and castings at your favorite hobby store.

Design Preservation Models
P.O. Box 66
Linn Creek, MO 65052