

**Building Parts Included in Kit**

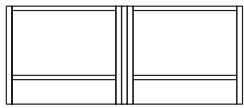

Street Level Blank Wall (3)

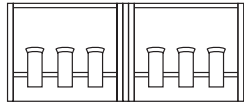

Street Level Window Wall (1)

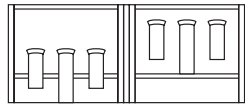

Street/Dock Level Entry Door Wall (2)

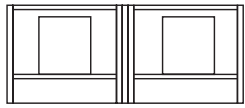

Dock Level Freight Door Wall (1)

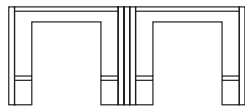

Street Level Freight Door Wall (1)



Dock Riser Wall (3)



Cornice (3)



Entry Doors with Windows (2)



Window (2)



Freight Door (2)



Dock Door (2)

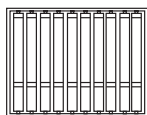

Street Level Pilaster (5)

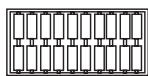

Dock Pilaster (2)

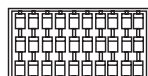

Cornice Pilaster (2)

**Additional Material**

- Roof supports 2-.08 sticks 4 1/2" length
- Inside corner strip 1-.060 stick 5" length
- Roof material 2 sheets-3 1/2" x 3 1/2"
- Dock floor and ramp 1 sheet-8" x 1"
- Clear window material 2 sheets-2" x 3"
- Black paper 1 sheet-7 3/4" x 4 1/2"
- 2 Decal sheets

See other side for Detail Parts List.

**OLSEN FEEDS AND LARSEN'S IMPLEMENT INSTRUCTIONS**

Follow these step-by-step instructions to construct the Olsen Feeds and Larsen's Implement buildings. Refer to Olsen Feeds Walls 1-6 and its Front and Back Views. Also refer to Larsen's Implement Walls 7-10, and to its Front and Back Views (illustrated below) to determine the proper location for each building's parts. The building parts included in this kit are identified on the left.

Match letters on the drawings below to determine where walls join. For example: Wall 1, Edge B and Wall 2, Edge B join each other as an "outside" corner (see Olsen Feeds Front View). Wall 4 - Edge F and Wall 5 - Edge F join each other as an "inside" corner (see Olsen Feeds Back View).

In Step 3, some walls, cornice and dock risers shown in drawings will need to be cut into two pieces to form bays (Walls 1, 3, 4, 5, 6, 8 and 10). You will have some wall parts (bays), pilasters, windows and dock walls left over when your buildings are completed.

Look through the enclosed catalog to see the complete line of DPM N scale buildings, as well as the wall sections that are interchangeable with and/or can be added to this building.

**OLSEN FEEDS**

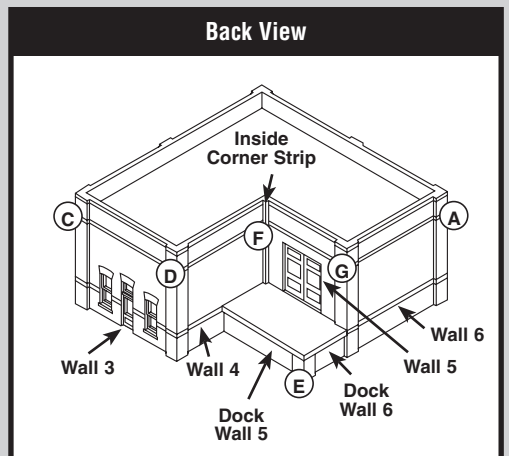
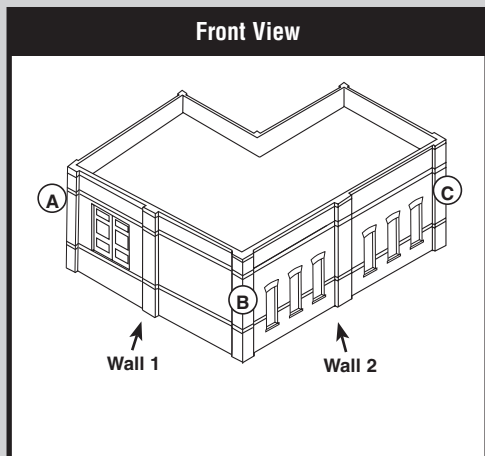
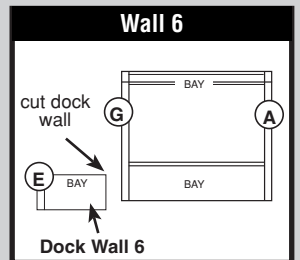
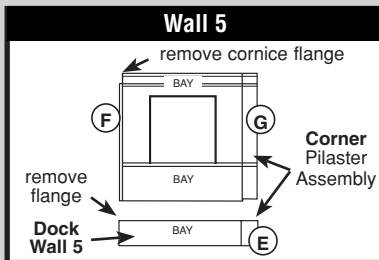
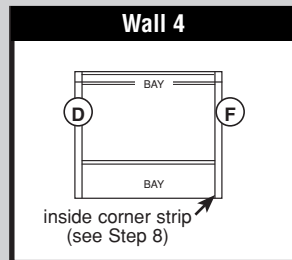
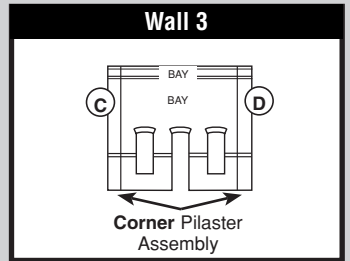
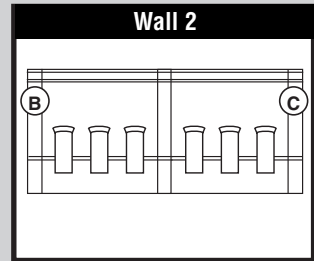
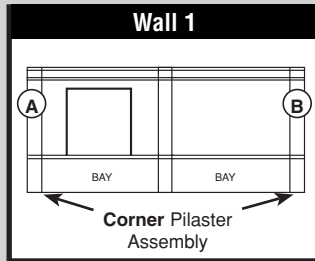

**LARSEN'S IMPLEMENT**

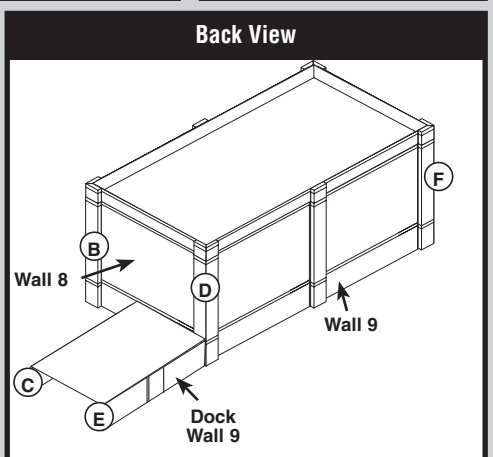
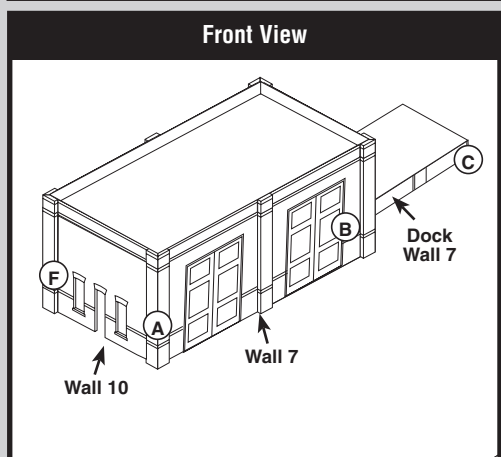
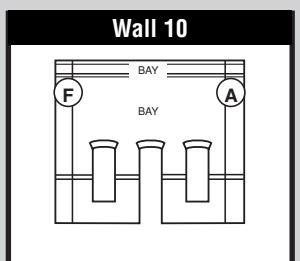
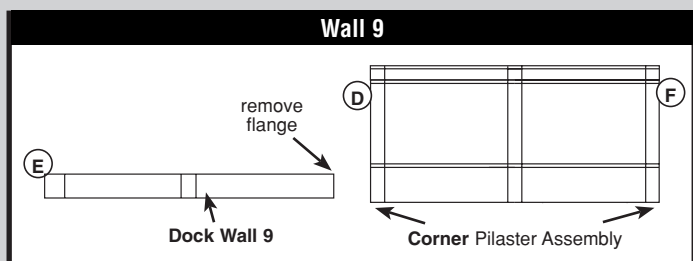
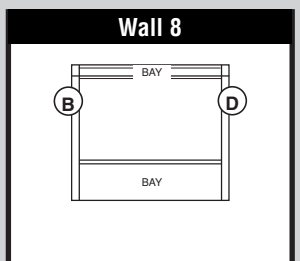
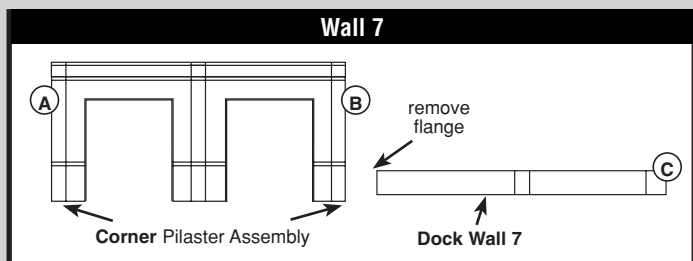

# 1 Prepare parts.

It is extremely important to carefully prepare parts before you begin to build. Parts will not fit properly if not prepared. Time spent now correctly preparing parts will help you build a better model.

Use a hobby knife or diagonal cutters to remove excess plastic created by the molding process (Fig.1).

Remove excess plastic from edges of recessed area in middle of wall sections, if needed.

Be sure to remove excess plastic on back edges of wall pilasters to square them so they will fit in recessed areas on wall sections.

Do not cut into detail or alter edges of parts.

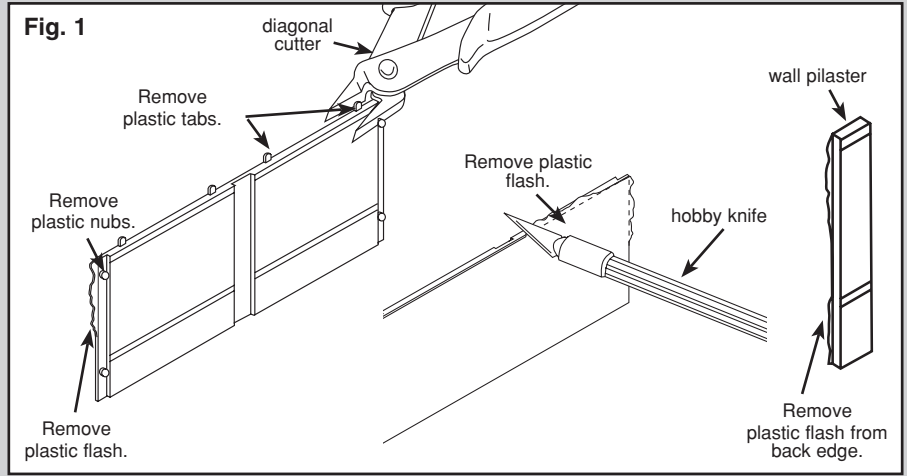

# 2 Identify all wall sections needed to build each wall (see illustrations of Walls 1 through 10) and place them in separate wall groups.

All N scale wall sections are molded two bays wide. Many walls in these buildings are only one bay wide; one wall panel (Wall 1) is assembled using bays from different wall sections (Figs. 2A and 3B). Therefore, some wall sections must be cut apart to form two separate bays (in Step 3).

In Step 5, bays and/or wall sections will be joined together side-by-side with wall pilasters to form wall panels (Fig. 2B). In Step 8, walls and cornices will be vertically joined to form an entire wall (Fig. 2C).

Complete Steps 3 and 4. Then, beginning with Olsen Feeds Wall 1, follow Steps 5 - 9 to build all Walls 1-6, constructing one wall at a time. Complete Olsen Feeds through Step 12. Larsen's Implement: Build Walls 7-10. Finally, paint and detail both buildings.

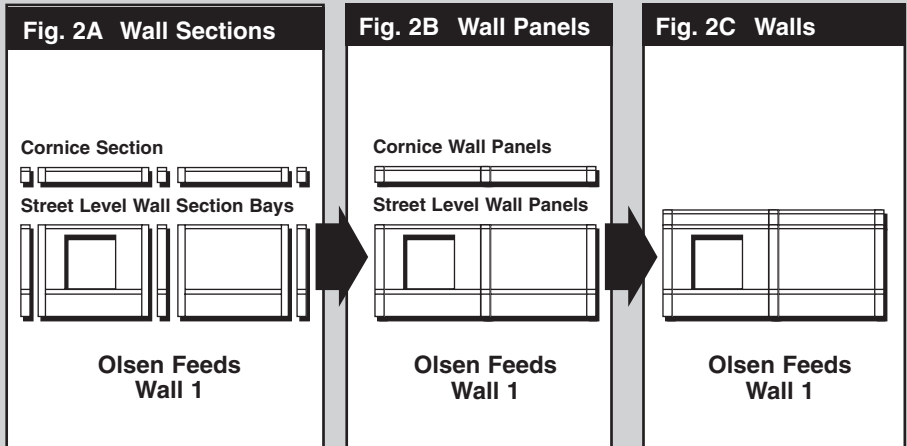

# 3 Make wall bays by cutting wall sections apart where necessary.

Note that Walls 4 and 6 each use one-half of the same wall section.

To separate wall sections into bays, score with hobby knife in the middle of recessed area of wall section and snap bays apart (Fig. 3A).

Make each bay shown in Fig. 3B.

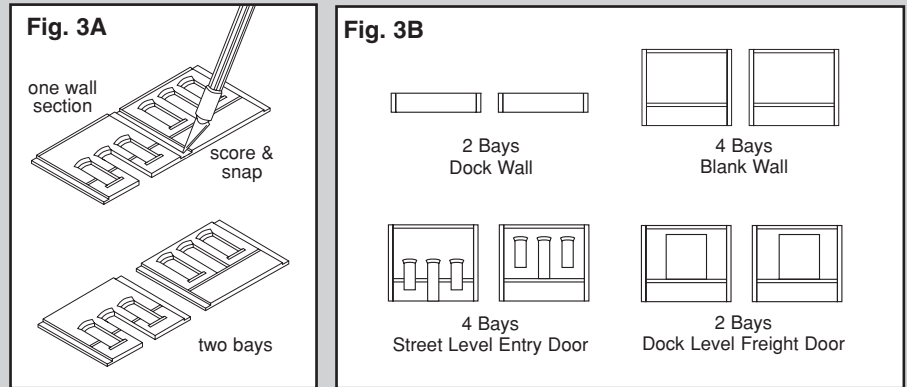

# 4 Glue all complementary corner pilasters together.

NOTE: Each pilaster sprue contains two left and two right corner pilasters and six wall pilasters (Fig. 4A). Each corner pilaster has a 45-degree angle on one long side.

Make the quantity of each type of corner pilaster shown in Fig. 4C by gluing complementary left and right corner pilasters together with plastic cement or solvent to make corner pilaster assemblies. Suggestion: Use a squaring block or a small square to ensure a 90-degree angle (Fig. 4B). Allow to dry. Glue street level left corner pilasters to street level right corner pilasters, cornice left corner pilasters to cornice right corner pilasters (Fig. 4C). Set assemblies aside until later.

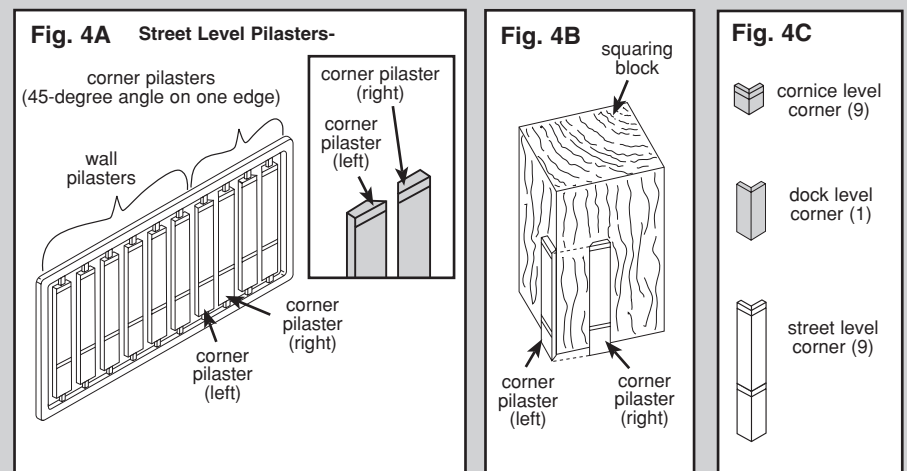

# 5 On Walls 1, 2, 7 and 9, use wall pilasters as joiners and glue to wall sections and bays, forming wall panels.

Use a straightedge to align sections at their tops (5A), one wall panel at a time.

See 5B for the right way (no gap) and wrong way (gap) to attach wall pilasters. Don't force wall pilasters into recessed areas of wall sections; they should fit easily. Be sure recessed area and pilasters are free of excess plastic (see Step 1 - Prepare parts again if necessary).

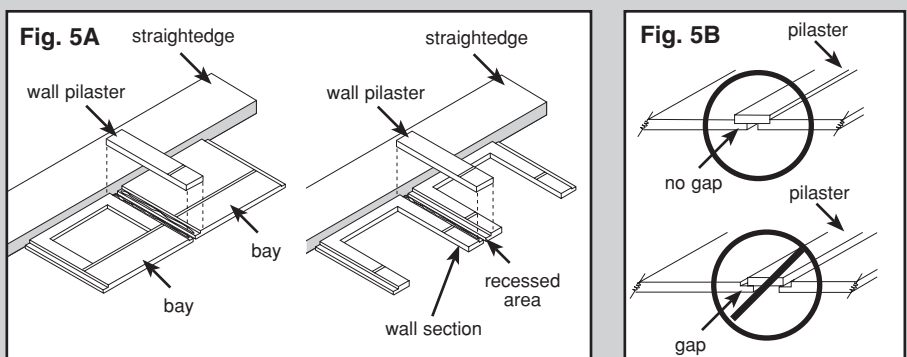

## 6 Glue corner pilaster assemblies to wall panels on both sides of Walls 1, 3 and right side only of Wall 5 (Fig. 6A). Repeat on both sides of Walls 7 and 9.

Before beginning to assemble Wall 5, remove cornice flange on left side of wall (Fig. 6B).

Fig. 6A

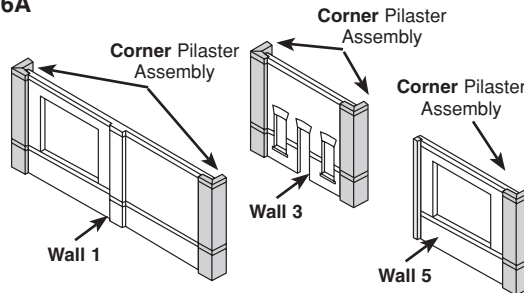
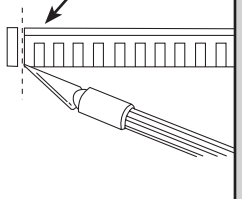

Fig. 6B

Cut off cornice flange on Wall 5.



## 7 Sand top and bottom of each assembled wall panel to align and square up all wall section edges (Fig. 7A).

NOTE: This step is essential to achieve proper fit later.

Tack 100-grit sandpaper to flat surface. Make sanding area longer than longest wall.

Use squaring block to keep edges flat and panels square as you sand (Fig. 7B). Move the wall panel, not the squaring block.

Do not sand into details.

Fig. 7A

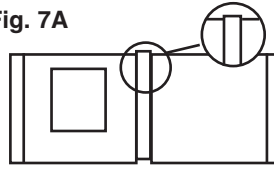

before sanding

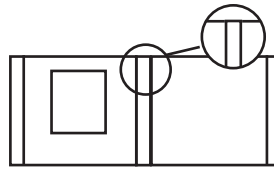

after sanding

Fig. 7B

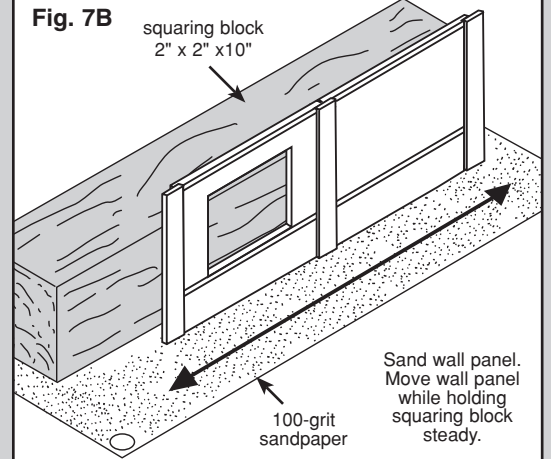

Sand wall panel. Move wall panel while holding squaring block steady.

## 8 Glue cornices and wall panels together to form entire wall.

Align pilasters and glue cornice panel to top wall panels (Fig. 8A).

Entire wall is now assembled (Fig. 8B).

Fig. 8A

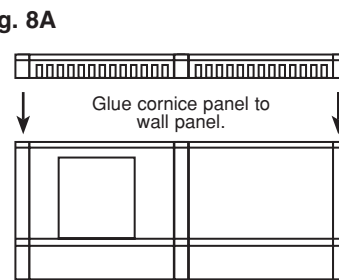

Glue cornice panel to wall panel.

Fig. 8B

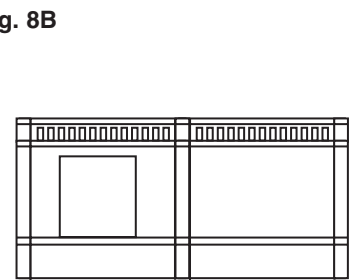

## 9 Attach corner strip to Wall 4, Edge F only.

Score with hobby knife and snap off a piece of the included 5" .060" styrene strip to a length that slightly overhangs top and bottom of Wall 4. Glue to flange (Fig. 9B).

Using a squaring block as shown in Step 7, sand flange to remove excess plastic until flange is flush with attached styrene strip (Fig. 9B).

Using a squaring block, sand ends of strip that overhang wall until flush (9C).

Repeat Steps 5 - 8 for remaining walls until all walls of both buildings are completed.

Fig. 9A

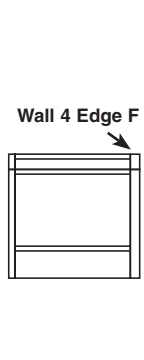
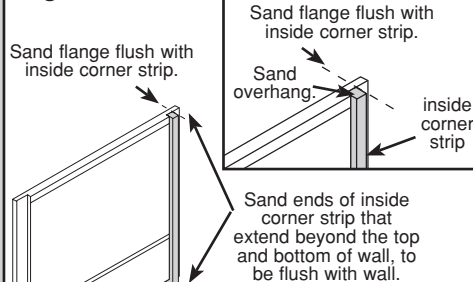

Fig. 9B



Sand flange flush with inside corner strip.

Sand flange flush with inside corner strip.

Sand overhang.

inside corner strip

Sand ends of inside corner strip that extend beyond the top and bottom of wall, to be flush with wall.

Fig. 9C

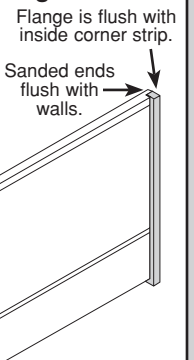

Flange is flush with inside corner strip.

Sanded ends flush with walls.

## 10 After all walls are assembled, glue them together to form complete buildings.

Use a squaring block to hold corners square while gluing (Fig. 10A).

Join Walls 4 and 5 together at installed corner strip to form inside Corner F. Join rest of walls together to form complete Olsen Feeds building (Fig. 10B). Repeat with Larsen's Implement building.

Optional: If desired, fill voids in corners at top of wall sections with spackle or plastic putty.

Fig. 10A

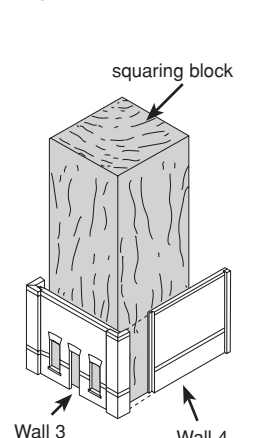

squaring block

Wall 3

Wall 4

Fig. 10B

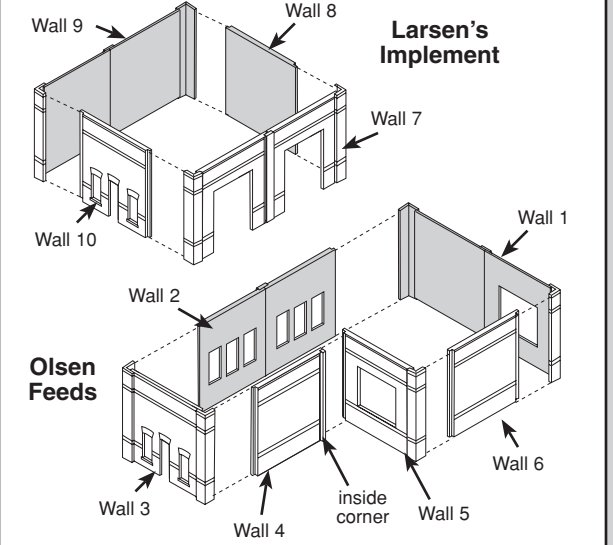

Wall 9

Wall 8

Larsen's Implement

Wall 7

Wall 10

Wall 2

Olsen Feeds

Wall 3

Wall 1

Wall 6

Wall 4

inside corner

Wall 5

## 11 Trace roof openings on roof material and cut out roof pieces.

Turn building upside down. Align a corner of building with two edges of one piece of roof material (Fig. 11A) and trace opening. Repeat with other building. Score with hobby knife and snap roofs apart, test fit and adjust. Set roofs aside.

To make roof supports: Use a hobby knife to score pieces of two 4 1/2" .080" styrene strips (included). Snap apart and glue to back side of walls, aligning top edge of strips with bottom edge of cornice (Fig. 11B).

Fig. 11A

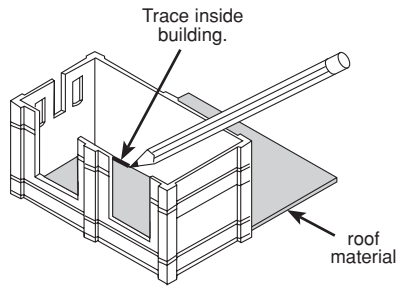
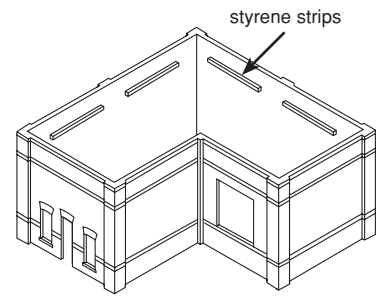

Fig. 11B



## 12 Assemble Olsen Feeds dock Walls 5 and 6. Cut and fit dock floor.

Dock floors will overlap dock walls slightly and cover tops of dock pilasters.

Assemble dock walls in the same manner as wall panels. Important Note: Olsen Feeds building serves as one side wall and back wall of its dock (Fig. 12A). To make dock Wall 6, cut a dock wall section to a length slightly less than width of dock floor (1 inch, Fig. 12B). Glue assembled dock walls to building (Fig. 12A).

Notch dock floor to fit around building's pilaster and installed corner strip (Fig. 12C). Do not glue dock floor in place yet.

See Step 14 to assemble and attach Larsen's Implement dock and ramp now.

Fig. 12A

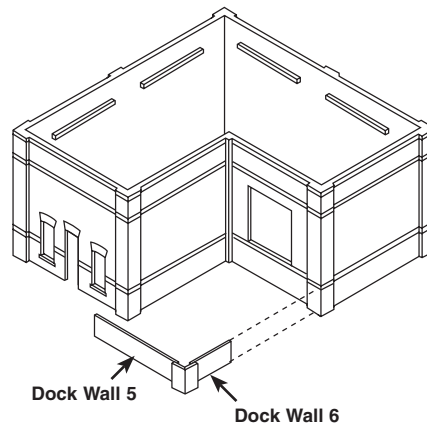
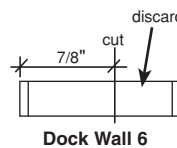
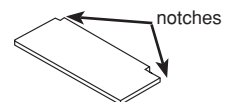

Fig. 12B Dock wall section



Dock Wall 6

Fig. 12C Dock floor



### Paint building parts.

We recommend that you paint all building parts for the most realistic appearance. However, it is not mandatory.

See Painting under Finishing Touches for helpful hints.

Doors and windows are easier to paint if left on sprues. When paint is dry, remove windows and doors from sprues.

Clean paint from surfaces to be glued. Touch up paint if needed.

## 13 Glue window frames and doors with windows to clear window material. Install all doors, windows, dock floors, ramp floor and roofs.

When gluing window frames to clear window material, allow 1/8" between each set (Fig. 13B). Keep glue off detail and window material that will be seen from the outside of building. When glue is dry, cut sets of windows and doors apart.

Note that each set of windows has a tab on top side (Fig. 13A). Windows are installed with tabs facing up. Install windows and doors, including freight doors, from the inside of building (Fig. 13C).

Glue both buildings' dock floors to their respective dock walls. Butt Larsen's ramp floor to dock floor and glue in place. Glue roofs to corresponding buildings (Fig. 13D).

Black paper, placed diagonally from corner-to-corner inside both buildings will complete the illusion that the buildings are occupied. Cut black paper (included in kit) to fit and install it.

Fig. 13C

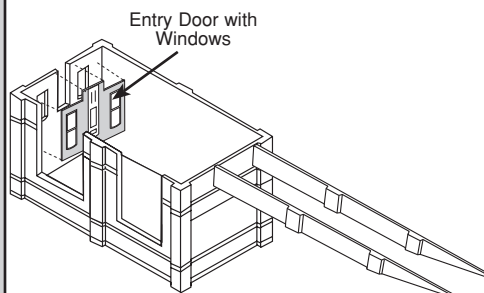

Fig. 13A

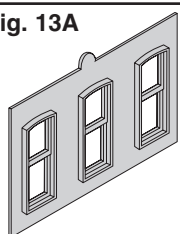

Fig. 13B

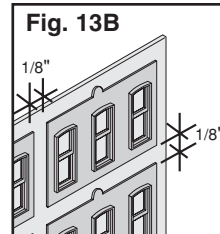
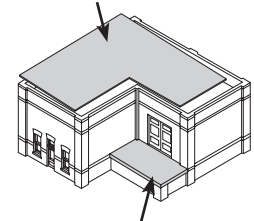
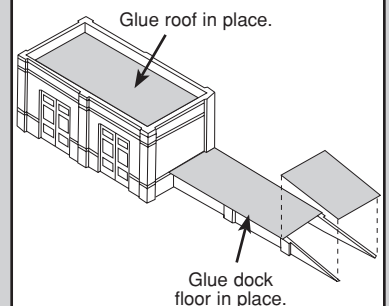

Fig. 13D

Glue roof in place.



Glue dock floor in place.



## DETAILS PARTS LIST

The following list contains all details included in the #66100 building. Sort and organize individual detail parts. This will make assembly easier.

	No.	Name	Qty		No.	Name	Qty	
<b>RAMP</b>	1	Left Ramp Support.....	1	<b>CYCLONE</b>	18	Cyclone.....	1	
<b>SUPPORTS</b>	2	Right Ramp Support.....	1		<b>MISCELLANEOUS PARTS</b>	19	Large Awnings.....	3
<b>TRACTORS</b>	3	Rear Wheels.....	8	20		Small Awnings.....	2	
	4	Tractor Body.....	4	21		Chimney.....	1	
<b>FARM WAGON</b>	5	Wagon Bed.....	1	22		Roof Hatch.....	1	
	6	Wagon Frame.....	1	23		Wall Vent.....	1	
	7	Wagon Rack.....	1	24		Roof Vents.....	4	
<b>COMBINES</b>	8	Combine Body.....	2	25		Dock Crane.....	1	
	9	Large Front Wheels.....	4	26		Seed Bag Pile (type 1).....	1	
	10	Rear Wheel Sets.....	2	27		Seed Bag Pile (type 2).....	2	
	11	Engine.....	2	28		Propane tank.....	1	
	12	Cab.....	2	29		Barrels.....	6	
	13	Auger.....	2	30		Pallets.....	8	
	14	Bats.....	4	31		Light Pole.....	1	
	15	Header.....	2	32		Gas Pump Island.....	1	
<b>FUEL TANK</b>	16	Tank Supports.....	2					
	17	Tank.....	1					

## ASSEMBLING DETAILS

### PREPARING LEAD-FREE WHITE METAL CASTINGS

Remove parting lines, flash and stems with a hobby knife, diagonal cutters, sandpaper or file. Align and fit castings. Note: Castings bend easily and should be handled carefully. To straighten bent or warped castings, lay them flat on a table and push down to table top.

Wash all metal castings in soapy water to remove residue caused by molding process. Rinse and allow parts to dry.

Plan ahead. It is often easier to pre-paint certain castings before assembly. We recommend using a primer coat and then painting castings with a high quality, flat paint. If you pre-paint, scrape paint from glue points before gluing. Touch up paint if necessary after assembly. See PAINTING under FINISHING TOUCHES for some helpful hints. Glue castings together with a fast-setting epoxy, or a cyanoacrylate such as super glue. We recommend a thick, gap-filling cyanoacrylate.

## 14 Add ramp walls to the Larsen's Implement dock walls.

Glue Details Parts 1 and 2 to flanges on ends of dock Walls 7 and 9 (Fig. 14A) to make ramp walls.

Attach dock Walls 7 and 9 directly to building (Fig. 14B).

Cut a piece of dock material to fit length of dock and notch it to fit building's pilaster. Cut another piece of dock material to fit length of ramp. Do not attach these floors yet.

Go back to PAINT BUILDING PARTS and Step 13 sections to finish both buildings.

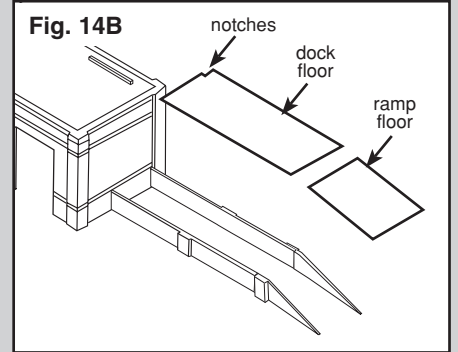
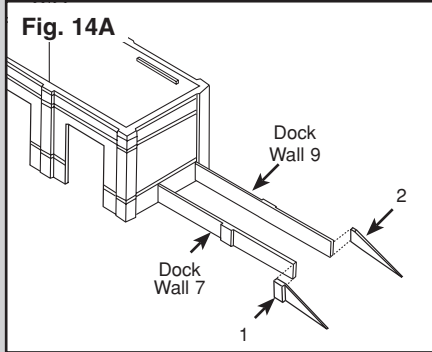

## 15 Assemble tractor and farm wagon.

Glue one Part 3 to each side of a Part 4 (Fig. 15A). Be sure tires are aligned so tractor will sit level.

Repeat with other three tractors.

Glue underside of Part 5 to Part 6 (Fig. 15B).

Glue Part 7 to Part 5 on the end opposite from the tongue, and with the five-sided warning sign on Part 7 facing to the rear.

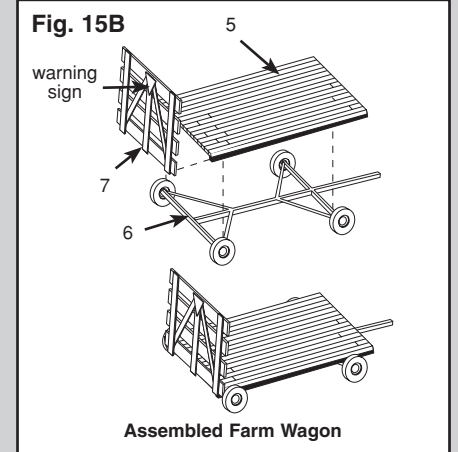
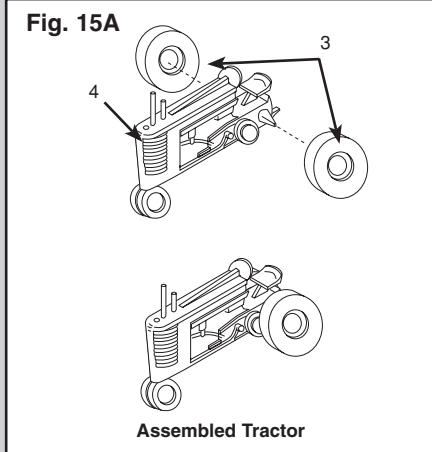

## 16 Assemble combine.

Glue one Part 9 to each side of Part 8 (Fig. 16A). Be sure wheels are aligned and straight so combine sits level side to side (front will be lower than rear of combine).

Glue Part 10 in notch on bottom of Part 8 (Fig. 16A). Be sure Part 10 is level.

Glue Part 11, Part 12 and Part 13 to Part 8 where shown in Fig. 16B.

Fit and glue two Part 14s together at cutout notch in center of each (Fig. 16C). Be sure all bats are parallel to each other as viewed from one end (Fig. 16C).

Glue assembled Part 14s to square plate on each end of Part 15 so that each bat (on the Part 14s) is glued to one corner of each plate (Fig. 16C.) Glue Part 15 to Part 8 (Fig. 16D).

Repeat with other combine.

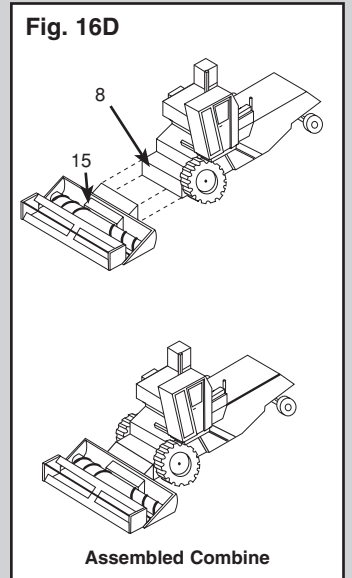
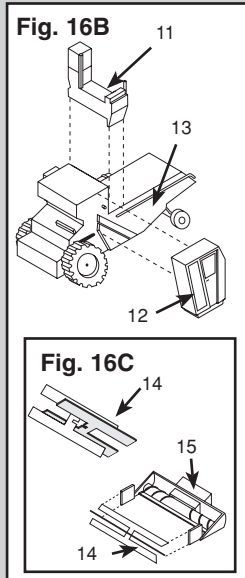
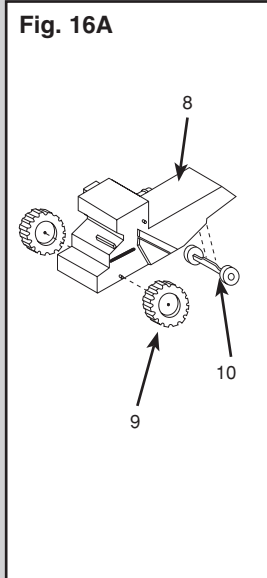

## 17 Assemble fuel tank.

Assemble fuel tank by gluing two Part 16s to bottom of Part 17 (Fig. 17). Place fuel tank where desired.

Fig. 17

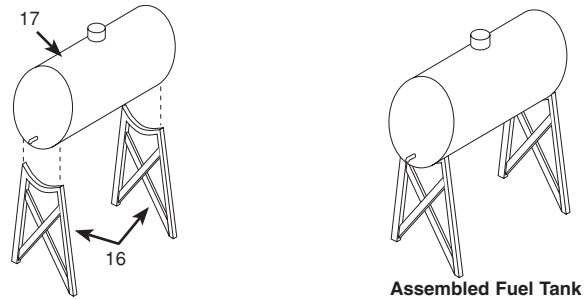

## 18 Glue all assemblies and Parts 18-32 in place on or around building.

Install Part 18 so it appears that lower tube goes through side of building (Fig. 18A).

Glue the three large awnings (Part 19s) above each of the three service doors shown in Figs. 5A & 5B. Glue small awnings (Part 20) on Walls 3 and 10 (Fig. 18B).

Glue Parts 21 - 24 to buildings as shown in Figs. 18A and 18B, or where desired.

Glue Part 25 to dock as shown in Fig. 18B, or where desired.

Glue Parts 26 - 31 as shown in picture on front of package or wherever desired (not shown in drawings).

If desired, use leftover dock material to make a concrete pad for Part 32 and place where shown in picture on front of package (or wherever desired).

Fig. 18A

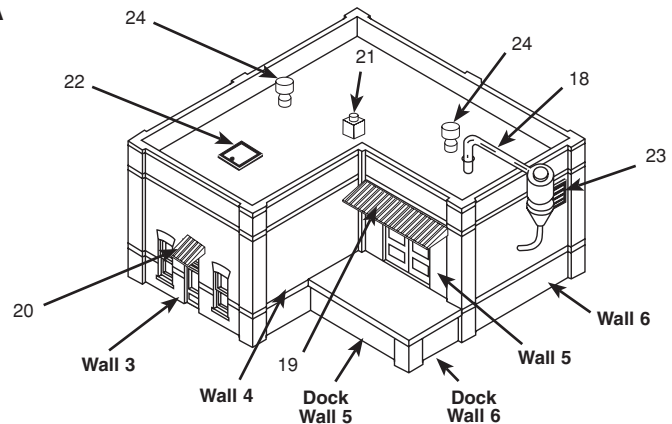
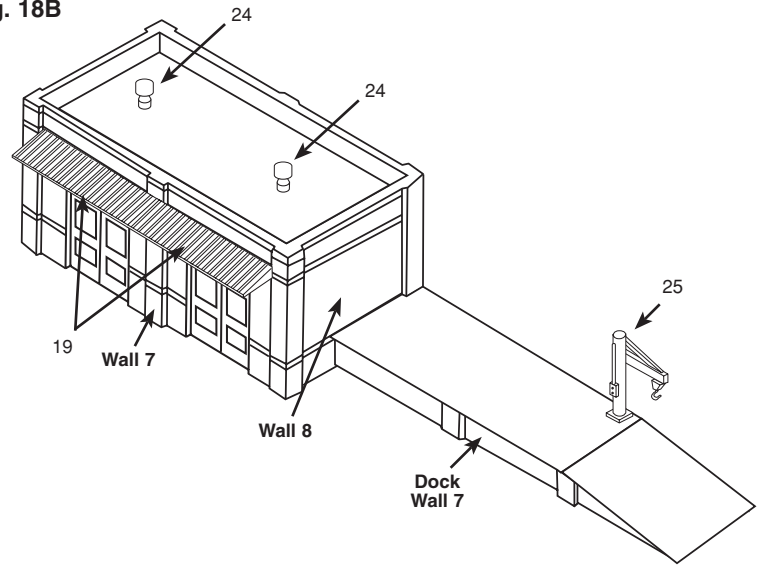

Fig. 18B



## FINISHING TOUCHES

### PAINTING

The appearance of buildings is enhanced by painting. We recommend airbrushing with solvent-based enamel paints, such as Floquil, in a flat finish. Use water-soluble flat paint such as Polly 'S' for brushing (color is your choice). We prefer natural brick colors in earth tones for buildings and the dock walls. Other suggestions: dock floors - Floquil "Concrete," roofs - "Flat Black". The color of window and door frames can match or contrast with the building. Buildings may be aged with chalks or lightly misted by airbrushing with thinned flat black paint such as Floquil "Grimy Black." Small details, painted a contrasting color, will add realism and enhance appearance. See the picture on the box for painting ideas. Scrape paint from glue points as necessary.

### OPTIONAL IDEA

You may want to apply very fine sand to the roofs to simulate a "gravel" texture.

Masking tape, placed on inside surface of windows at various heights from top of the windows, simulates window shades and gives the building an occupied appearance.

### DRY TRANSFER DECALS

- Place the Dry Transfer Decal in the position shown in the picture on the front of the package, or where desired.
- Hold the carrier sheet gently so it cannot move while you rub over the decal with a burnisher or dull pencil.
- Carefully remove the carrier sheet. If the transfer was incomplete, let the sheet fall back into place and transfer the remainder.
- Place backing paper over the decal and reburnish. Repeat with other decals.

**NOTE:** The cast details and Dry Transfer Decals in this kit were made by Woodland Scenics. See the entire line of Dry Transfer Decals and castings at your favorite hobby store.

Design Preservation Models  
is a division of:  
**Woodland Scenics®**

P.O. Box 98, Linn Creek, MO 65052  
www.woodlandscenics.com • www.dpmkits.com