

STEAM ENGINE AND HAMMER MILL - D229



Add color, interest and authenticity to any layout with finely crafted HO scale vintage details. Scenic Details® are lead-free metal castings, easy to assemble and fun to paint.

Step-by-step instructions are included in each kit. To assemble, use super glue or fast-setting epoxy. To paint, use Mini-Scene® Paint Set (M125).

Other HO scale scene reproductions include Trackside Scenes™, Complete Scenes™ and Mini-Scene®.

For more information and to learn more tips and techniques, read *The Scenery Manual (C1207)* or visit woodlandscenics.com.

GENERAL INSTRUCTIONS

Clean and Fit Castings - Castings have parting lines, flash and stems that should be removed. Scrape off with a hobby knife, file or sand. If Castings do not align properly, fit them by removing metal with a hobby knife or file. Castings are somewhat brittle and should be handled carefully. If Castings are bent or warped, straighten by placing on a flat surface and pushing down high areas. Prior to gluing and painting, wash Castings in warm, soapy water, rinse and let dry.

Glue Castings - Glue Castings with cyanoacrylate adhesive (CA glue / super glue) or a fast-setting epoxy.

Prime and Paint Castings - Prime all Castings and let dry. If primer beads on Casting, touch paintbrush to a bar of wet soap and then dip in paint. This will help break surface tension of paint, allowing it to adhere to the casting. We recommend painting Castings with the Mini-Scene® Paint Set (M125). It includes detailed instructions on painting and weathering. High-quality, flat hobby paints will also work. Plan ahead. It is often easier to pre-paint Castings. Scrape paint from glue points prior to assembly.

INSTRUCTIONS

Read General Instructions before assembly.

1. Clean and fit castings.
2. Prime and paint as desired. Let dry completely.
3. Position Parts 2 and 3 on Part 1. Verify pipes on Parts 2 and 3 align properly. Glue in place. (Fig. 1)
4. Install and glue Part 4 onto stem on Part 2. Ream hole in Part 4, if necessary.
5. Align and glue together Parts 5 and 6.
6. Place Hammer Mill and Steam Engine in desired location on layout. Drive Wheels on both parts should align (Fig. A). Position Wheels 3/4" apart.
7. Cut a strip of black construction paper (not included) 3/32" wide and long enough to wrap around both Drive Wheels and overlap enough for securing.
8. Wrap paper strip around both Flywheels (making a loop) and glue in place (Fig. 2).

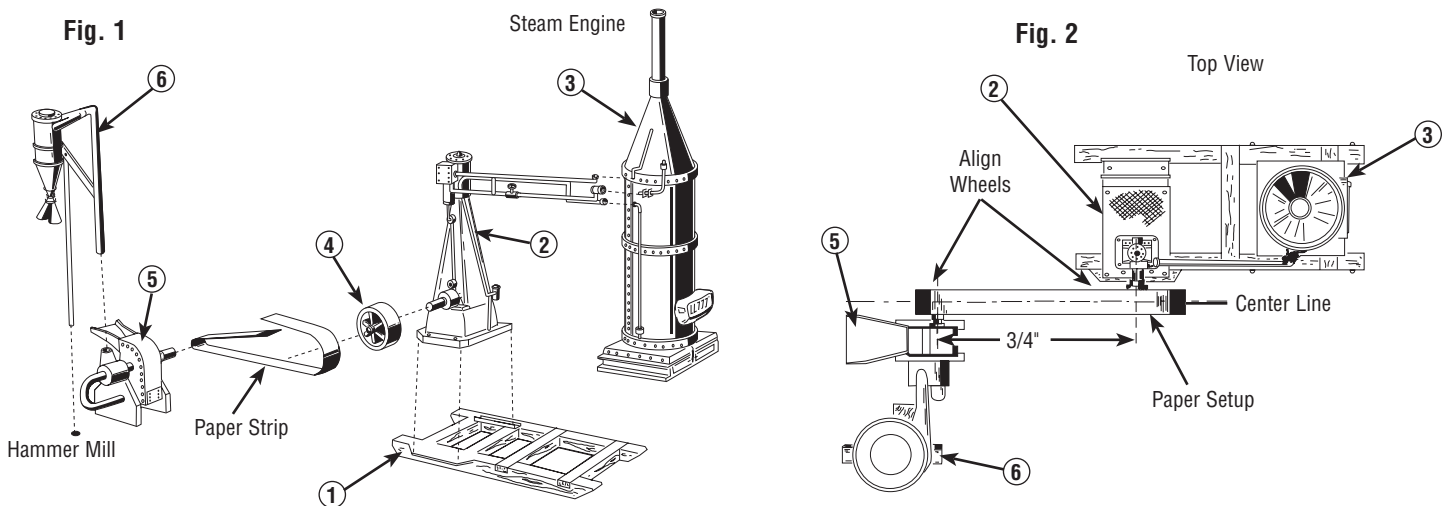

CAUTION: Tools recommended.
Use with care.

This item is not a Children's Product and is not intended for use by Children.

MODELING AND CARE INFORMATION: This kit suggests the use of materials that may stain or cause damage. Take care to cover project area and clothing appropriately. Follow recommendations for use and clean up.

Made in USA F4 ©1990 O CO

WOODLAND SCENICS® PO BOX 98, LINN CREEK, MO 65052 • woodlandscenics.com